

Original Article

Battery Management System (BMS) with Thermal Protection

J. Sabari Ganesh¹, Dr. S M Rajkumar², S. Rakesh³

¹Master of Engineering in Industrial safety Engineering, Francis Xavier Engineering College.

^{2,3}Associates Professor, Mechanical Engineering, Francis Xavier Engineering College.

Received Date: 25 February 2026

Revised Date: 06 March 2026

Accepted Date: 30 March 2026

Abstract: With the increasing use of rechargeable batteries in electric vehicles, renewable energy storage, and portable electronics, efficient and safe battery operation has become critical. This project presents the design and implementation of a Battery Management System (BMS) with integrated thermal protection to ensure reliable performance and extended battery life. The proposed hardware system monitors key battery parameters such as voltage, current, state of charge (SoC), and temperature using dedicated sensors. A microcontroller-based control unit processes the data to balance individual cells, prevent overcharging, deep discharging, and short circuits. Thermal protection is achieved by integrating temperature sensors and heat management circuits, which trigger cooling mechanisms or disconnect the battery during overheating conditions. Additional safety features include fuse/circuit breaker protection and relay-based isolation. The system communicates real-time battery health information through an optional display or wireless module, enabling proactive maintenance. The design emphasizes compactness, low cost, and energy efficiency, making it suitable for electric vehicles, solar energy storage, and smart grid applications.

Keywords: Battery Management System (BMS), Thermal Protection, State of Charge (SoC), Cell Balancing, Overcharge Protection, Temperature Monitoring, Electric Vehicles.

I. INTRODUCTION

To address these safety and reliability challenges, a Battery Management System (BMS) is used as an intelligent control and protection unit for modern battery. The rapid growth of modern technology has led to an extraordinary increase in the use of rechargeable batteries in a wide range of applications such as Electric Vehicles, renewable energy storage systems, portable electronic devices, medical instruments, and industrial automation. Among the different battery technologies available today, Lithium-ion Battery has emerged as the most preferred energy storage solution due to its high energy density, lightweight structure, low self-discharge rate, and long cycle life. However, despite these advantages, lithium-based batteries are extremely sensitive to operating conditions such as voltage, current, and temperature. Improper charging, deep discharging, short circuits, or excessive heat can severely degrade battery performance, reduce lifespan, and in extreme cases lead to hazardous conditions such as fire, explosion, and thermal runaway. Therefore, ensuring the safe, reliable, and efficient operation of batteries has become a critical requirement in today's energy-dependent world.

A BMS continuously monitors key battery parameters such as voltage, current, temperature, and state of charge (SoC), and ensures that the battery always operates within its safe operating limits. It plays a vital role in protecting the battery from abnormal conditions like overcharging, overcurrent, deep discharge, and overheating. In conventional battery systems, protection is often limited to simple fuses or basic voltage regulators, which are not sufficient for handling complex fault conditions, especially in high-capacity battery packs used in electric vehicles and renewable energy systems. As energy demand and battery usage continue to increase, the need for intelligent, automated, and real-time battery monitoring and protection has become more important than ever.

Among the various risks associated with battery operation, thermal instability is one of the most dangerous and challenging problems. Excessive temperature rise inside a battery can cause internal chemical reactions to accelerate uncontrollably, leading to a dangerous phenomenon known as Thermal runaway. Once initiated, thermal runaway can rapidly escalate into fire or explosion, especially in lithium-ion batteries. Hence, integrating thermal protection into the battery management system is essential for preventing catastrophic failures and ensuring user safety. Temperature monitoring using intelligent sensors, along with automatic disconnection of the battery during abnormal thermal conditions, forms the core of a safe and effective BMS. In addition to local protection, modern applications also demand remote monitoring, predictive maintenance, and smart communication capabilities using emerging technologies such as the Internet of Things (IoT).

In this context, the proposed project focuses on the design and implementation of a Battery Management System with integrated thermal protection and IoT-based monitoring. The system is capable of continuously monitoring voltage, current, state of charge, and temperature of the battery in real time, and automatically taking protective actions whenever unsafe conditions are detected. By combining intelligent sensing, microcontroller-based control, automatic relay isolation, local LCD



display, and wireless communication, the proposed BMS not only enhances battery safety but also improves energy efficiency, operational reliability, and battery lifespan. This makes the system highly suitable for critical applications such as electric vehicles, solar energy storage systems, UPS/inverter units, and smart grid infrastructure where battery reliability and safety are of utmost importance.

II. WORKING PRINCIPLE

The working principle of the Battery Management System (BMS) with Thermal Protection and IoT Monitoring is based on the continuous real-time supervision of the electrical and thermal parameters of a Lithium-ion Battery used for driving a DC load or vehicle system. When the battery is connected to the system, its terminal voltage and load current are first sensed through dedicated voltage and current sensing circuits that scale and condition the high battery values into safe low-level analog signals suitable for the analog-to-digital converter of the ATmega328P. Simultaneously, the battery temperature is continuously measured using a digital temperature sensor, the DS18B20, which directly provides precise thermal data to the controller.

The microcontroller continuously samples these parameters, compares them with predefined safe operating limits stored in its program memory, and calculates the real-time operating condition of the battery such as healthy state, over-voltage, under-voltage, over-current, and over-temperature. Under normal operating conditions, when all parameters remain within safe limits, the controller allows normal power flow by activating the relay through the ULN2003A driver circuit, thereby connecting the battery to the DC load. At the same time, all real-time values of voltage, current, and temperature are displayed on the 16x2 LCD for local monitoring and are also transmitted wirelessly through the ESP8266 NodeMCU to a cloud server or mobile application for remote monitoring. If the battery voltage exceeds the upper charging threshold, the system identifies an over-voltage condition and immediately deactivates the relay to stop charging, thereby preventing overcharging and thermal stress. Similarly, if the battery voltage drops below the minimum safe discharge limit, the controller isolates the load to avoid deep discharge, which is one of the major causes of battery degradation. In the case of abnormal current rise due to short-circuit or heavy overload, the current sensor detects the sudden increase, and the controller instantly trips the relay to protect both the battery and connected load.

Thermal protection plays a critical role in the system's safety operation; when the temperature sensor detects overheating beyond the preset limit, the microcontroller immediately disconnects the battery from the load and charging source, thereby preventing thermal runaway, fire hazards, and permanent battery damage. Along with electrical isolation, fault status messages such as "Over Voltage," "Over Current," or "Over Temperature" are displayed on the LCD and simultaneously uploaded to the IoT platform to alert the user in real time. Once the fault condition returns to a safe range, the system can either automatically reconnect the battery or wait for manual reset depending on the programmed logic. Thus, through continuous sensing, intelligent decision-making, automatic switching, local display, and remote communication, the proposed BMS ensures safe charging and discharging, enhances battery life, prevents hazardous failures, and enables reliable, smart energy management for electric vehicles, renewable energy storage systems, and advanced battery-powered applications.

III. SYSTEM IMPLEMENTATION

A. Existing System

In the existing battery usage systems, rechargeable batteries used in Electric Vehicles, inverters, UPS units, and solar energy storage systems are generally operated with basic protection circuits that offer only limited safety features such as fuse-based overcurrent protection and simple voltage regulation. Most traditional systems monitor only the battery voltage and do not provide accurate real-time current measurement or continuous temperature monitoring. As a result, critical conditions such as overcharging, deep discharging, and internal overheating are not detected at an early stage. This absence of thermal monitoring often leads to serious problems like battery swelling, reduced capacity, electrolyte leakage, and thermal runaway in lithium-based batteries. In many existing systems, protection mechanisms are purely manual, where the user must physically disconnect the battery during faults.

There is also no remote monitoring facility, meaning battery health cannot be observed from a distant location. Furthermore, cell balancing is not implemented, which causes unequal charging of battery cells, leading to reduced lifespan and poor energy utilization. Due to the lack of intelligent control and automation, existing systems suffer from low safety, reduced battery life, higher maintenance cost, and increased risk of fire accidents.

B. Proposed System

The proposed system introduces an advanced Battery Management System (BMS) with Thermal Protection and IoT Monitoring that overcomes all the limitations of the existing system. It continuously monitors battery voltage, current, and temperature in real time using dedicated sensors and processes the data using the ATmega328P. Unlike conventional systems,

the proposed design provides automatic protection against overcharging, deep discharging, overcurrent, and overheating by controlling a relay through a driver circuit.

The inclusion of the DS18B20 enables accurate thermal protection, ensuring that the battery is instantly isolated during overheating conditions to prevent thermal runaway and fire hazards. A 16x2 LCD displays real-time battery parameters and system status for local monitoring, while the ESP8266 NodeMCU provides remote monitoring through IoT, allowing users to view battery health and receive fault alerts on a mobile device or cloud platform.

The system also supports automatic recovery after fault clearance and improves battery lifespan, safety, reliability, and energy efficiency. The proposed BMS is compact, low cost, intelligent, and highly suitable for applications in electric vehicles, renewable energy storage, UPS systems, and smart grid environments.

IV. PROJECT DESIGN

A. Block Diagram

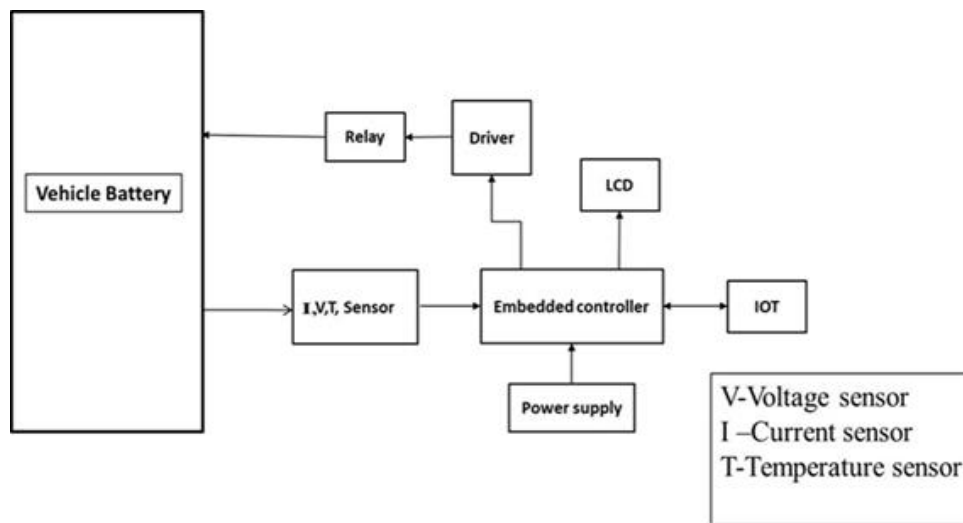

Figure 1: Proposed Block Diagram

The block diagram illustrates the complete working architecture of a Battery Management System (BMS) with Thermal Protection designed for safe operation of a vehicle battery. The vehicle battery, typically a Lithium ion Battery, is the primary energy source, and its key parameters are continuously monitored using the V-I-T sensor unit, where the voltage sensor measures the terminal voltage of the battery, the current sensor monitors charging and discharging current, and the temperature sensor (such as LM35 or DS18B20) tracks the battery temperature in real time to detect overheating. All these sensor signals are fed into the embedded controller, which is usually a microcontroller such as ATmega328P or a similar control unit. This controller acts as the brain of the system, processing sensor data, comparing it with predefined safety thresholds, calculating battery health parameters like state of charge, and making real-time protection decisions. When the controller detects abnormal conditions such as overvoltage, undervoltage, excessive current, or high temperature, it sends a control signal to the driver circuit, which amplifies the low-power control signal from the microcontroller to a level sufficient to operate the relay. The relay acts as an electrically controlled switch that physically connects or disconnects the battery from the load or charging source, thereby providing electrical isolation and protecting the battery from damage during fault conditions. The LCD display, such as a 16x2 LCD, is interfaced with the controller to display real-time values of voltage, current, temperature, and system status such as “charging,” “discharging,” “overheat,” or “fault,” enabling easy local monitoring. The IoT module, commonly implemented using devices like ESP8266, allows wireless transmission of battery data to a cloud server or mobile application, enabling remote monitoring, alerts, and predictive maintenance. The entire system is powered by a regulated power supply unit, which converts the raw battery voltage into stable low-voltage DC (such as 5 V or 3.3 V) required for the microcontroller, sensors, and communication modules. Thus, the integration of sensing, processing, display, communication, and protection elements in this block diagram ensures continuous battery supervision, automatic fault isolation, and enhanced thermal and electrical safety, making the system suitable for electric vehicles, renewable energy storage, and smart battery applications.

B. Circuit Diagram

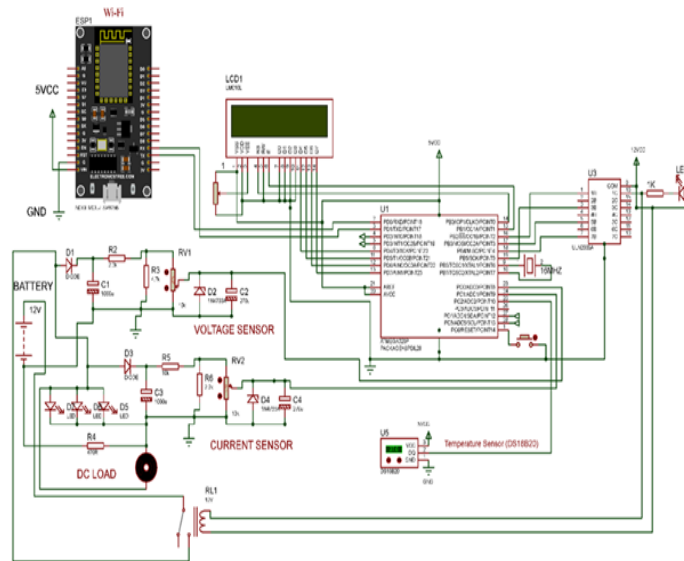

Figure 2: Proposed Circuit Diagram

The given circuit diagram represents the complete hardware implementation of a Battery Management System (BMS) with Thermal Protection and IoT Monitoring, designed to monitor, protect, and control a 12 V battery used for DC load or electric vehicle-type applications. The heart of the system is the ATmega328P microcontroller, which continuously acquires analog and digital signals from the voltage, current, and temperature sensing circuits, processes the data using embedded logic, and takes real-time protection decisions. The power source of the system is a 12 V battery, which is first fed through protection and signal-conditioning networks. The voltage-sensing section consists of a diode (D1) for reverse-polarity protection, filter capacitor C1 for ripple suppression, and a resistive divider network formed by R2, R3, and the variable resistor RV1. This divider scales down the high battery voltage to a safe 0–5 V range compatible with the ADC of the ATmega328P. The Zener diode D2 and capacitor C2 provide over-voltage clamping and noise filtering before the scaled voltage is fed into the microcontroller’s analog input. This allows the controller to compute the real-time battery voltage and determine over-charge or under-voltage conditions accurately.

The current-sensing section operates in a similar way, where the load current flowing through the DC load passes via a sensing network consisting of diode D3, resistor R5, filter capacitor C3, fixed resistor R6, and preset RV2. The small voltage developed across this network is proportional to the load current and is filtered using C4 and clamped using Zener diode D4 to ensure safe ADC input levels. This signal is then sent to another ADC pin of the ATmega328P to continuously monitor charging or discharging current. The DC load is driven through protective LEDs and a current-limiting resistor R4, which also provides visual indication of load operation. Through continuous sampling of voltage and current, the microcontroller can calculate key parameters such as power consumption, battery stress, and fault conditions like over-current or short circuit.

Thermal protection is implemented using the DS18B20, which is directly interfaced to one of the digital I/O pins of the ATmega328P using the One-Wire communication protocol. The temperature sensor is powered with a regulated 5 V supply and continuously measures the battery or heat-sink temperature with high accuracy. If the temperature exceeds the predefined safety threshold, the microcontroller immediately initiates a protection sequence by disabling the relay and isolating the battery from the load, thereby preventing thermal runaway, fire hazards, or permanent battery damage. This closed-loop thermal monitoring forms the core safety feature of the BMS.

For switching and isolation, the system uses a 12 V relay (RL1), which physically connects or disconnects the battery from the DC load. Because a microcontroller pin cannot directly drive a relay coil due to current limitations, the relay is controlled through the ULN2003A driver IC. The ULN2003A amplifies the low-current control signal from the ATmega328P to a level sufficient to energize the relay coil. It also provides built-in flyback diodes to suppress the inductive voltage spikes generated when the relay is switched off, thereby protecting the microcontroller from damage. A visual indication of relay activation is given using LED1 with a 1 k Ω current-limiting resistor.

User interaction and real-time system monitoring are achieved through a 16x2 LCD (LM016L). The LCD is connected to the ATmega328P in 8-bit parallel mode using data lines Do–D7 and control lines RS and EN. A potentiometer is used for contrast adjustment. The LCD continuously displays battery voltage, load current, temperature, and system status such as

“Normal,” “Over-Voltage,” “Over-Current,” or “Over-Temperature.” This provides immediate feedback to the user without requiring external instruments.

For wireless monitoring and IoT integration, the circuit includes the ESP8266 NodeMCU module. The microcontroller sends real-time battery parameters to the ESP8266, which in turn uploads the data to a cloud server or mobile application over Wi-Fi. This enables remote monitoring of battery health, temperature, voltage trends, and fault alerts from anywhere in the world. Such IoT integration is highly useful in electric vehicles, solar battery banks, and smart grid systems where physical inspection is not always possible.

V. APPLICATIONS AND ADVANTAGES

A. Applications

- Used in Electric Vehicles to continuously monitor battery voltage, current, and temperature for safe and reliable driving operation.
- Applied in solar energy storage systems to protect battery banks from overcharging during daytime and deep discharge during low generation periods.
- Implemented in UPS and inverter systems to ensure proper battery charging, safe discharging, and uninterrupted backup power supply.
- Used in industrial battery banks for continuous condition monitoring and remote supervision through Internet of Things technology.
- Employed in portable electronic devices and power packs to enhance user safety and maintain stable battery performance.

B. Advantages

- Extends battery life by protecting it from overcharging, deep discharging, and excessive current stress.
- Improves system safety by providing fast and automatic protection against electrical and thermal faults.
- Allows real-time monitoring of battery parameters both locally on display and remotely through wireless communication.
- Reduces maintenance effort and cost through automatic fault detection, isolation, and remote diagnostics.
- Increases overall system reliability and energy efficiency by ensuring safe operating conditions at all times.

VI. CONCLUSION

The proposed Battery Management System with Thermal Protection and IoT Monitoring has been successfully designed to provide a safe, reliable, and intelligent solution for modern battery-powered applications. By continuously monitoring critical parameters such as battery voltage, current, and temperature, the system ensures that the battery always operates within safe limits and is protected from hazardous conditions like overcharging, deep discharging, overcurrent, and overheating.

The use of the ATmega328P as the core control unit enables accurate data processing, fast decision-making, and automatic control of the relay for immediate fault isolation. The integration of thermal protection using precise temperature sensing prevents thermal runaway and significantly reduces the risk of fire and battery failure.

Furthermore, the inclusion of IoT through the ESP8266 transforms the system into a smart, connected platform that allows real-time remote monitoring, alert notifications, and data logging through the internet. The local LCD display also provides clear visual feedback of battery parameters and system status for easy user interaction.

Overall, the developed system improves battery safety, enhances operational efficiency, extends battery lifespan, and reduces maintenance requirements. Hence, the proposed Battery Management System with Thermal Protection is a highly effective, economical, and scalable solution for electric vehicles, renewable energy storage systems, UPS units, and other critical battery-based applications.

VII. REFERENCES

- [1] S.-J. Na, J.-U. Sim, B.-J. Kim and I.-H. Cho, “Design of Bluetooth Communication-Based Wireless Battery Management System for Electric Vehicles,” *IEEE Access*, vol. 12, pp. 185946–185957, 2024, doi: 10.1109/ACCESS.2024.3512669.
- [2] H. Walvekar, H. Beltran, S. Sripad and M. Pecht, “Implications of the Electric Vehicle Manufacturers’ Decision to Mass Adopt Lithium-Iron Phosphate Batteries,” *IEEE Access*, vol. 10, pp. 63834–63843, 2022.
- [3] Y. Ma, Q. Ma, H. Ding, Y. Hu and H. Chen, “Multi-layer NMPC for Battery Thermal Management Optimization Strategy of Connected Electric Vehicle Integrated with Waste Heat Recovery,” *IEEE Transactions on Intelligent Transportation Systems*, vol. 25, no. 6, pp. 6133–6146, 2024

- [4] Z. Sun, Y. Guo, C. Zhang, H. Xu, Q. Zhou and C. Wang, "A Novel Hybrid Battery Thermal Management System for Prevention of Thermal Runaway Propagation," *IEEE Transactions on Transportation Electrification*, vol. 9, no. 4, pp. 5028–5038, Dec. 2023, doi: 10.1109/TTE.2022.3215691.
- [5] S. Krishnakumar, A. Kumar, N. Selvarani, G. Satish, R. RamanChandan, H. Hemavathi and M. Sivaramkrishnan, "IoT-based Battery Management System for E-Vehicles," in *Proc. 3rd Int. Conf. Smart Electronics and Communication (ICOSEC)*, Tiruchirappalli, India, 20–22 Oct. 2022, pp. 428–434, doi: 10.1109/ICOSEC54921.2022.9952052.
- [6] M. S. Kale and B. N. Chaudhari, "IoT Based Battery Monitoring System," in *Proc. 2022 Int. Conf. Advances in Computing, Communication and Materials (ICACCM)*, 2022, pp. 1–5, doi: 10.1109/ICACCM56405.2022.10009576.
- [7] S. Rathod and M. S. Aspalli, "PV Sourced Battery Management System with IoT Based Real Time Monitoring System for Electric Vehicle," in *Proc. 2022 IEEE 2nd Int. Conf. Mobile Networks and Wireless Communications (ICMNWC)*, Dec. 2022, pp. 1–6.
- [8] H. Bashir, F. Yusof and A. Rahman, "A Review of Battery Management System and Modern State Estimation Approaches," in *Proc. 2022 IEEE Int. Conf. Electrical and Computer Engineering (ICECE)*, Dhaka, Bangladesh, 2022.
- [9] B. Spoorthi and P. Pradeepa, "Review on Battery Management System in EV," in *Proc. 2022 Int. Conf. Intelligent Controller and Computing for Smart Power (ICICCSP)*, Hyderabad, India, 21–23 Jul. 2022.
- [10] V. R. Murlidharan, J. Karnati and H. Malik, "BMS Threat Modeling, Vulnerability Analysis, and Cybersecurity Strategy," *IEEE Access*, vol. 13, pp. 144322–144336, 2025, doi: 10.1109/ACCESS.2025.3543249.