

borraOriginal Article

# Smart Grid DC Ultra-Fast Charging Stations for Automotive and Industrial Inverters

P. RanjithKumar<sup>1</sup>, M. Sangeetha<sup>2</sup>, M. Bharathidasan<sup>3</sup>

<sup>1</sup>Dept. of Mechanical Engineering, M.A.M. School of Engineering, Tamilnadu, India.

<sup>2,3</sup>Dept. of Electronics and Communication Engineering, M.A.M. School of Engineering, Tamilnadu, India.

**Abstract:** The DC-to-DC bi-directional resonant converter showing this project is intended for use in bi-directional power transfer applications, particularly those involving the charging and discharging of batteries in electrical vehicles. It is comparable to an LLC resonant converter, but in order to achieve bi-directional capability, a second inductor and capacitor were added to the circuit's secondary side, making the resonant network symmetric so that it could operate both forward and backward. It is assured that the switches in the inverting step have zero voltages switching (ZVS). Additionally, under ZCS, these secondary side rectifier diodes switch off. Reduced losses and high frequency operation made possible by ZVS and ZCS cause magnetic components and filter capacitors to shrink in size, which in turn reduces their weight, volume, and dimension while enhancing power density. In order to thoroughly analyze the converter's voltages and currents, an analog us model of the converter is first created in this project. Next, the converter is simulated in order to confirm that the conceptual designs sound.

**Keywords:** Smart Grid, DC, Industrial Inverters.

## OBJECTIVE

This project proposes to develop an isolated bi-directional DC-DC converter using a series connection of bidirectional DC converters. These soft switching converters provide a broad duty ratio, zero current transition (ZCT) for turning off all switching devices, high voltage gain with less voltage stress across the switches, and intrinsic voltage balance at the two poles of the DC bus. Because soft-switching is available with this converter. On the other hand, power transfer via the LLC resonant converter is unidirectional. Its gain is limited to less than unity while in reverse mode operation. The CLLC bidirectional resonant converter is a unique architecture that has been researched and used in a few energy storage applications. A low-voltage symmetric LLC-type resonant architecture has been proposed.

## Hybrid Power EV/PHEV

But because of its relatively limited voltage range, it cannot be used in an EV or PHEV application.

A large voltage range CLLC architecture was suggested and used in the 400V/48V input/output continuous power supply system. However, due to the large disparity between the input and output voltages, its transformer ratio is impractical in battery charging applications. This work presents a bi-directional DC/DC converter of the CLLC type that satisfies all on-board criteria.

## Hybrid Power System Bus

Electricity bus is a good conductor in made into a bus-bar for transporting energy from power generator/converter to the grid. Hybrid renewable energy power system (HRES) has two levels of voltage bus the DC and AC produced by the mixture and crossbreed of energy resources.

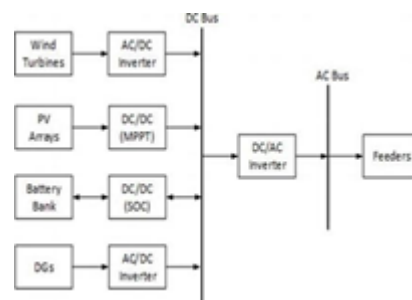

*Parallel hybrid RE system with both AC and DC bus for only all AC loads*



The above figures are in one line/block schematic representing three phase system for hybrid RE resources to produce output voltage waveform shown in Figure 1.5. However, hybrid RE can be also designed to supply single phase system for smaller single phase load demand and its output voltage wave is single implied.

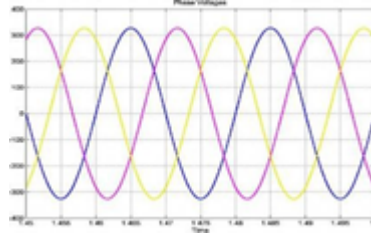

*Hybrid RE three phase output voltage wave forms.*

Hybridizing is a common strategy for improving the sizing of renewable resource (RER) energy resources; it is also known as cross breeding in the SPV. The optimum scale of renewable energy resource to harvest energy reliably depends on the optimal design of conversion model. Energy converters are RER and come with assorted characteristics, sizes, and brands guide in the design and the implementation of projects. The RER characteristics of solar photovoltaic and micro hydro are the main focal area to be considered for discussion and analyses is in this study.

### **Problem Statement**

Bi-directional DC micro-grids are gaining popularity because of their high power handling capacity, adaptability to link loads of two different voltage levels, flexibility to connect multiple renewable energy sources (RES), and dependability. A suitable DC-DC converter with a high voltage gain and an easy-to-use management method is needed to manage bipolar DC micro-grids with energy storage devices. A high gain bi-polar bi-directional dc-dc converter is suggested to operate at greater voltage and power levels with less voltage stress across these switches; none the less, it causes electromagnetic interference (EMI) and offers the same voltage gain as uni-polar bidirectional converters. Although there is less voltage stress between the switches in the flying capacitor-based bipolar bidirectional converter suggested in, the voltage gain is the same as that of the unipolar converter that is bidirectional. In order to attain high voltage gain, a switching capacitor-based bipolar bidirectional converter is developed, however it also has significant current ripple and current stress throughout the device. The neutral point clamped three level inverter-based bipolar bidirectional converter suggested in a high voltage gain and a restricted duty ratio. A bidirectional medium voltage "ladder" with a DC-DC converter is suggested in order to get high voltage.

### **BLOCK DIAGRAM AND EXPLANATION**

Electricity cannot be mined from the ground like coal. So it is called a secondary source of energy, meaning that it is derived from primary sources, including coal, natural gas, nuclear fission reactions, sunlight, wind, and hydropower. Most direct uses of primary energy are limited to generating heat and motion. Electricity, by contrast, is extremely versatile, with a wide range of complex applications. Electricity plays such an essential role in contemporary American life that its supply and demand are often examined separately from the primary sources used to produce it.

### **Solar Energy**

The amount of sunlight that strikes the earth's surface in an hour and a half is enough to handle the entire world's energy consumption for a full year. Solar technologies convert sunlight into electrical energy either through photovoltaic (PV) panels or through mirrors that concentrate solar radiation. This energy can be used to generate electricity or be stored in batteries or thermal storage. Below, you can find resources and information on the basics of solar radiation, photo voltaic and concentrating solar-thermal power technologies, electrical grid systems integration, and the non-hardware aspects (soft costs) of solar energy. You can also learn more about how to go solar and the solar energy industry. In addition, you can dive deeper into solar energy and learn about how the U.S. Department of Energy Solar Energy Technologies Office is driving innovative research and development in these areas.

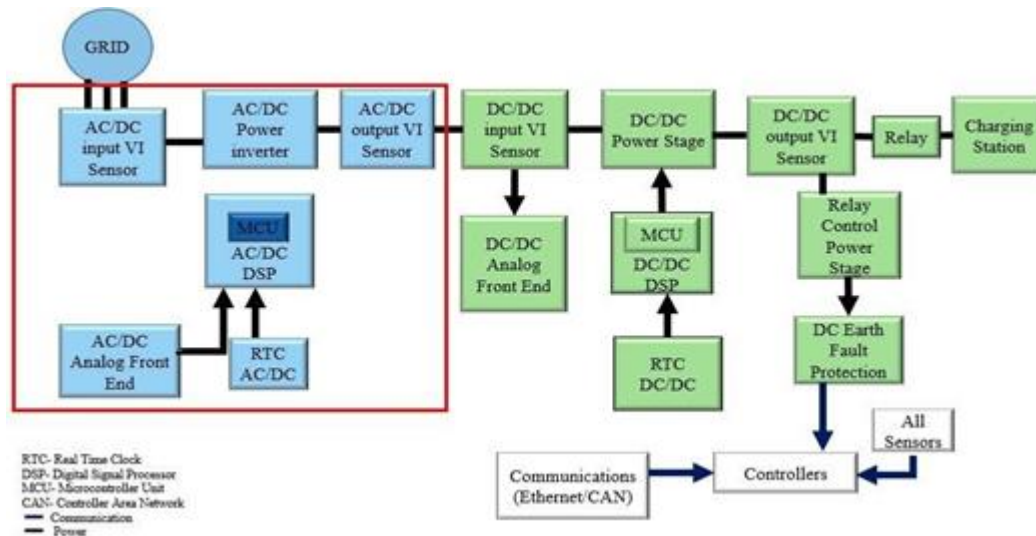

### WindEnergy

Wind is used to produce electricity by converting the kinetic energy of air in motion into electricity. In modern wind turbines, wind rotates the rotor blades, which convert kinetic energy into rotational energy. This rotational energy is transferred by a shaft which to the generator, thereby producing electrical energy. Wind power has grown rapidly since 2000, driven by R&D, supportive policies and falling costs. Global installed wind generation capacity – both onshore and offshore – has increased by a factor of 98 in the past two decades, jumping from 7.5 GW in 1997 to some 733 GW by 2018 according to IRENA’s data. Onshore wind capacity grew from 178 GW in 2010 to 699 GW in 2020, while offshore wind has grown proportionately more, but from a lower base, from 3.1 GW in 2010 to 34.4 GW in 2020. Production of wind power increased by a factor of 5.2 between 2009 and 2019 to reach 1412 TWh.

### Solar Micro DC/DC converter

The Solar Micro DC/DC Converter is a DC/DC converter per module which maximizes solar energy generated per system by performing Maximum Power Point Tracking (MPPT) per module. The Solar DC Micro converters can boost the total solar energy produced up to 30%. The Solar DC Micro converters measure the power and the energy produced per module, as well as the temperature and the voltage of the module. Each The Solar DC Micro converters is equipped with arc detection and determination, which automatically shuts down the module’s DC voltage in case either the module’s temperature or voltage is too high. [350V or 380V DC bus supported].

### DC-DC power converters

Various isolated bi-directional DC-DC power converters have been proposed, such as resonant converters, dual fly back, dual-Cuk, dual push-pull, and DAB [72]. Among them, the DAB converter is the most usable one in the DC-DC power stage of DC SST-based ultra-fast charging stations. The advantages of the DAB converter can be listed as bidirectional power flow capability and fast power flow mode changing, wide voltage conversion range to interface different voltage levels, and ZVS capability to increase the efficiency.

### EXISTING SYSTEMS

Traditionally, the renewable energy source is connected to the load through a traditional DC-DC converter and then the energy storage system is connected to either the input port or the output port of the traditional DC-DC converter through a bidirectional DC-DC converter for charging and discharging as shown in Fig. 1 (a) and Fig. 1 (b). The main disadvantage of these traditional solutions is the low efficiency due to the utilization of the additional converter for the energy storage system. Also, the multi-stage architecture may result in increased size, low power density, and relatively high cost.

A multi-input converter is a solution to satisfy their requirements of some applications that require the integration of several different types of input energy sources such as fuel cells, wind turbines, and solar PV. This type of converter can be used to provide the demanded power of the load with a single stage technique; however, no energy storage system is included in these multi-input converters, and hence the system may not be

able to meet the required load demand when the output power is greater than the input power. For fuel cell operation, this may happen when there is a sudden increase in load and the chemical reaction of the fuel cell is not fast enough to follow the increase in load. Similarly for solar PV application, there may be fast PV output fluctuation during passing cloud causing the PV output to be less than the load demand or when there is no sun irradiation at night. Wind power output also. Since all of the three ports are reconnected directly, this type of converter can only be used in those applications where galvanic insulation is not required. Another disadvantage of the non-isolated three-port converters is that most of these converters have a limited voltage gain since the freedom of modulation of the voltage conversion ratio is only the duty cycle. Some reported papers use coupled-inductor to extend the voltage conversion ratio to overcome this issue.

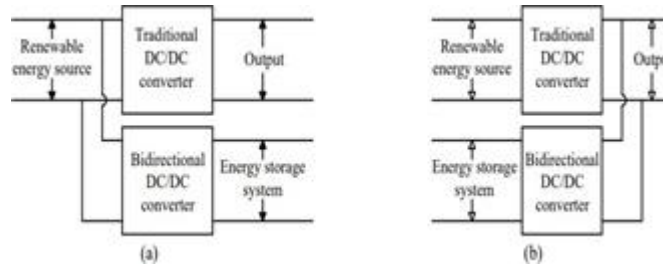

Traditional power electronic systems in renewable energy system, (a) type 1, (b) type 2

### Proposed System

The proposed converter is illustrated in It has a symmetric structure: the primary side circuit resembles the secondary side circuit connected by a symmetric high-frequency transformer. The switches  $Q_{i1} \dots Q_{i4}$  in the primary inverting stage convert power from dc to ac to transfer it through the high frequency transformer. Using this transformer, the converter achieves galvanic isolation between the primary side and the secondary side. The leakage inductance of the transformer's primary and secondary windings is incorporated into the resonant inductors  $L_{r1}$  and  $L_{r2}$ , respectively. In addition, Fig.4.1 shows power flow directions in the converter, which are defined as follows:

Power being transferred to the load from source (forward power flow direction) and power being transferred from source to load (backward power flow direction).

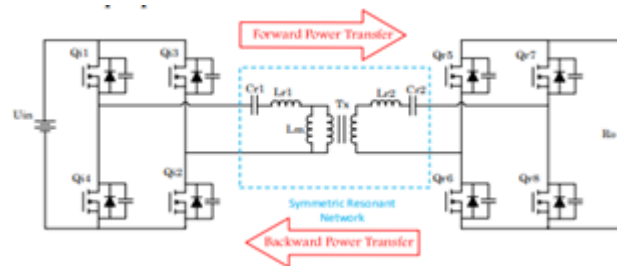

### Operation

The different operational intervals of the proposed bi directional CLLC resonant converter. This converter's operation has been divided into eight operational intervals during a single switching cycle. Intervals 1, 2, 3 and 4 repeat to intervals 4, 5, 6 and 7 with different inverting and rectifying switch pairs. Intervals 2,3 and 4 are dead-time durations, intervals 1 and 5 are power transfer modes. The primary switches work in the inverting mode when power is transferred from the primary to the secondary side; however, the secondary switches remain OFF and the anti-parallel diodes operate as rectifiers on the secondary side. Error! Reference source not found. Gives the or ethical waveforms showing the behavior of the converter for all intervals during a single switching cycle. In Error! Reference source not found, there are only the waveforms of the charging mode. However, in the discharging mode, the waveforms are precisely the same as the waveforms of the charging mode, because the primary inverting' side and the secondary rectifying beside are symmetric. Detailed explanation and description of the operational intervals are given below: Interval 1  $[t_0, t_1]$ : At the instant  $t_0$ , the switches  $Q_{i1}$  and  $Q_{i2}$  are conducting and power is transferred from the primary stage to the secondary stage.

Resonance takes place between the series elements  $C_{r1}$ ,  $L_{r1}$ ,  $L_{r2}$  and  $C_{r2}$ , and the resonant current  $i_{Lr1}$  rises in a sine-wave curve. The current in magnetizing inductor  $i_{Lm}$  also increases but resonates considerably

slower than  $i_{Lr1}$ . Thus  $L_m$  does not take part in the resonance phenomenon in this interval. On the secondary side, the rectified currents  $i_{Qr6}$  and  $i_{Qr7}$ , which are carried by the anti-parallel diodes of  $Qr6$  and  $Qr7$  are proportional to the difference between the terms  $i_{Lr1}$  and  $i_{Lm}$ . Interval 2 [ $t_1, t_2$ ]: After attaining its peak value,  $i_{Lr1}$  begins to decline and at the instant  $t_1$  becomes equal to the slowly rising magnetic current  $i_{Lm}$ .

The rectifier current on the secondary side decreases to zero, and the anti-parallel diodes of  $Qr6$  &  $Qr7$  turn off under ZCS. The voltage on the resonant capacitor  $Cr2$  also resonates to its peak with the absolute value of  $V_{Cr2}$ . It will remain unchanged unless it excites again in the next resonance. The free resonance between  $Cr1$ ,  $Lr1$ , and  $L_m$  on the primary side is avoided by the disconnection of  $Cr2$  and  $Lr2$ . Interval 3 [ $t_2, t_3$ ]: At time  $t_2$ ,  $Qi1$  and  $Qi2$  turn off.  $i_{Lr1}$  begins to charge the parasitic capacitance of  $Qi1$  and  $Qi2$ , and discharge that of  $Qi3$  and  $Qi4$  simultaneously. Since the value of the parasitic capacitance is small compared with that of the resonant capacitor  $Cr1$ , this time period is rather short with respect to the total switching period. Thus, the corresponding voltages on the afore mentioned capacitance rise/decrease rapidly. This stage ends up with  $v_{dQi1,2}$  reaching the input voltage and  $v_{dQi3,4}$  decreasing to zero. At the end of this stage, the voltage applied on the resonant tank has changed polarity from positive  $U_{in}$  to negative.

Interval 4 [ $t_3, t_4$ ]: When  $Qi3$  and  $Qi4$  are completely discharged, the resonant current  $i_{Lr1}$  immediately starts flowing through the anti-parallel body diodes of  $Qi3$  and  $Qi4$ , and is fed back to the input source. When the voltage of the magnetic inductor  $L_m$  resonates to reach the voltage of  $V_2 - V_{Cr2}$ , the rectifier switches  $Qr5$  and  $Qr8$  conduct, and the resonant capacitor  $Cr2$  and  $Lr2$  participate the resonance with the primary side again. At time  $t_4$ ,  $Qi3$  and  $Qi4$  turn on under ZVS conditions, the first-half switching period ends, and the converter enters the next (the second) half. Interval 5 to 8: In the next half cycle, the operation of the converter is the same as in the first half cycle, except that the other pair of switches in both the inverting and rectifying stages are operating in the second half.

### MATLAB Simulation & Results

MATLAB is the high-level language and interactive environment used by millions of engineers and scientists worldwide. It lets you visualize ideas disciplines including signals and image processing, communications, control systems, and computational finance. In SIMULINK, it is very straight forward to represent and then simulate a mathematical model representing a physical system. Models are represented graphically in SIMULINK as block diagrams. A wide array of blocks are available to the user in provided libraries for representing various phenomena and models in a range of formats. One of the primary advantages of employing SIMULINK (and simulation in general) for the analysis of dynamic systems is that it allows us to quickly analyse the response of complicated systems that may be prohibitively difficult to analyze analytically. SIMULINK is able to numerically approximate the solutions to mathematical models that we are unable to, or don't wish to, solve "by hand." In general, the mathematical equations representing a given system serve as the basis for a SIMULINK model can be derived from physical laws.

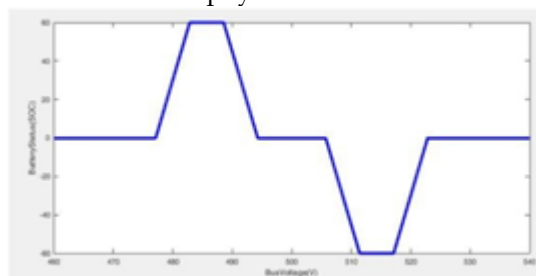

### Introduction to Simulink

SIMULINK is a software add-on to MATLAB which is a mathematical tool developed by The Math Works, (<http://www.mathworks.com>) a company based in Natick. MATLAB is powered by extensive numerical analysis capability. Simulink is a tool used to visually program a dynamic system (those governed by Differential equations) and look at results. Any logic circuit, or control system for a dynamic system can be built by using standard building blocks available in SIMULINK Libraries. Various toolboxes for different techniques, such as Fuzzy Logic Neural Networks, DSP, Statistics etc. are available with SIMULINK which enhance the processing power of the tool. The main advantage is the availability of templates building blocks, which avoid the necessity of typing code for small mathematical processes.

RESULTS AND DISCUSSION

PV Output Waveform MPPT

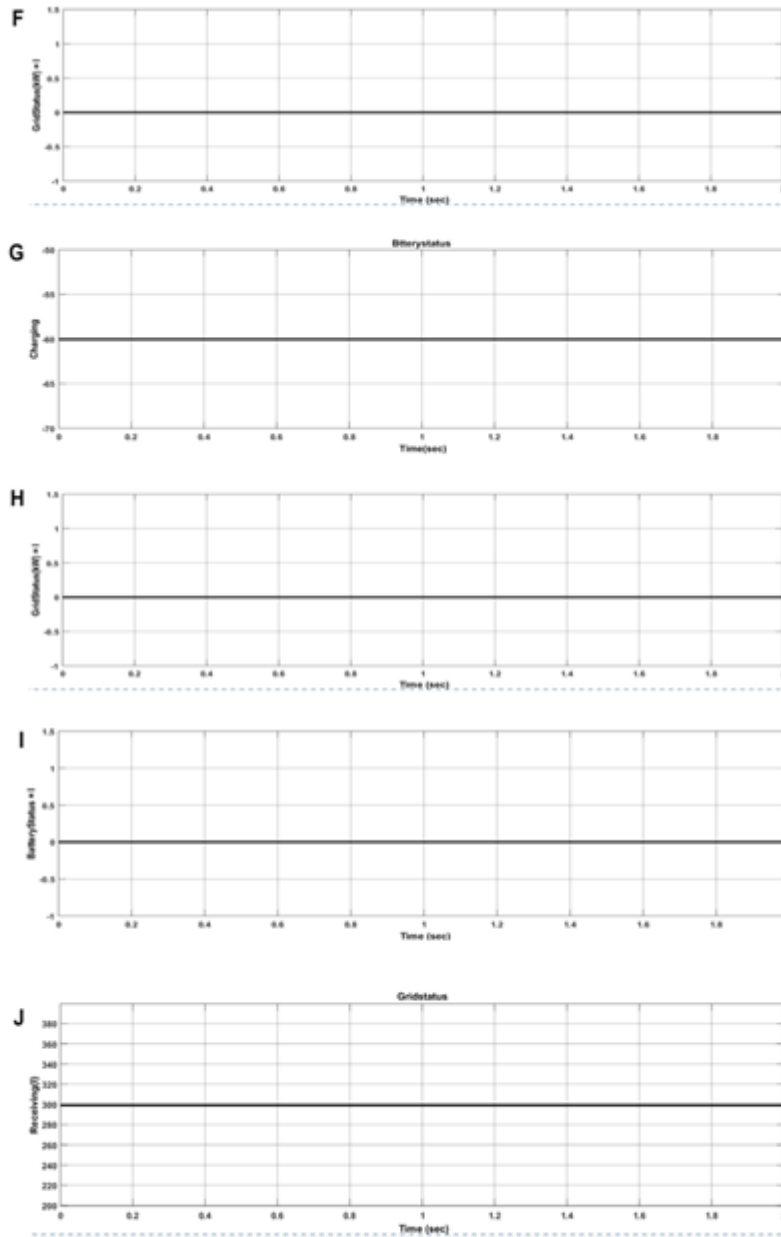

I have developed a mathematical model of PV module (200W) in discrete form. According to mathematical equations, a feedback is required thus, i have connected a unit delay block as feedback loop for voltage across terminals of current source. For an individual PV module it is working fine as desired and getting correct output waveform for current, voltage, power and IV/PV characteristic also. Then i connected an individual PV module with Boost converter and constant duty cycle is given for a selected set of parameters, then also the system is working properly. After that I connected PV module and Boost converter with MPPT(based on P&O method), any how the waveform of voltage, current and power is attending desired value after some delay and got IV-PV characteristic. But the problem arises when i am connecting 8 PVmodules to form a 4x4 PV array (3.2KW), with Boost converter and MPPT controller (based on P&O method).In this case for the selected set of parameters ,the voltage wave form is not responding and current waveform drops instantly to ZERO after 0.005

sec. Also, the duty cycle is settled down at fixed lower value. I tried for different set of values for associated parameters but result remains same, wave form is not responding after 0.005sec.

### Output and Storage of Battery Charging

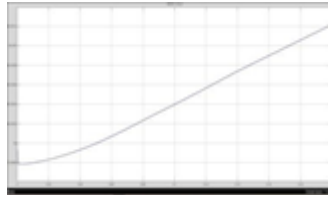

### Output and Storage of Battery Charging

Small power battery chargers for devices such as mobile phones, tablets and power tools are ubiquitous. All of these devices are examples of AC/DC converters. Sample 1 is a battery charger for an 18 V power tool battery whilst Sample 2 is a charger for a mobile phone. Both current wave forms, but especially that for Sample 2, have high distortion out to high order harmonics. A battery charger consists of a rectifier circuit, power circuit, ripple monitoring, control circuit, regulator circuit, and fault detection circuit. This charger can also be used as a DC source for a control and protection circuit of a substation during normal operation, or to charge the battery in floating mode. When there is a problem in the AC system, then the battery supplies the DC loads in a substation. There are two types of charging modes: the first is the fast charging for new or unused batteries, and the second is the floating charge to charge the batteries in service and supply a load to compensate for the small charge lost by the battery in service.

### Wind Grid Generating Power

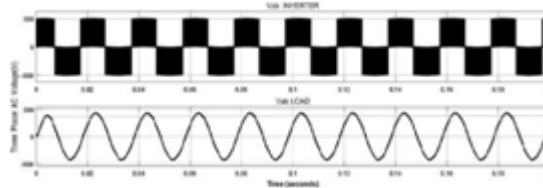

### Output Power for Wind Energy

## CONCLUSION

Regardless of the direction of power flow, the CLL-LC bidirectional DC-DC converter described in this work enables soft switching as zero voltage switching for the inverting stage and zero current switching for the rectifier switches. It also has a symmetric resonant tank. Because MOSFETs are the primary switches, the converter has lower switching losses and is completely number-less, resulting in smaller, lighter, and more compact design. The suggested converter's operating principles and simulations have been examined analyzed, and illustrated. The simulated converter has been demonstrated to display ZCS for the rectifying stage and ZVS for the inverting stage. The theoretical study and the converter's qualities are validated by the simulation results. In light of this, the converter presents itself as an alternate option that is especially well-suited for on-board battery charging and discharging applications in electrical vehicles because to its broad input range, increased efficiency, and high power density.

## REFERENCES

- [1] Mummadi Veerachary ; Vasudha Khubchandani, Year: 2019, "Analysis, Design, and Control of Switching Capacitor Based Buck-Boost Converter", IEEE Transactions on Industry Applications, vol.55, no.3, pp.2845-2857.
- [2] Sangeetha, M., Arivoli, R., and Karthikeyan, B., (2017), Neural Network Based UHVDC For Enhancement of Transient Compensation in Offshore Wind Power Plant, *Journal of Electrical Engineering*, Vol.17 No.2 (2017): Volume 17 / 2017, PP.446-45, ISSN 1582-4594 SJR, Scimago Journal Country Rank, <http://www.jee.ro/index.php/jee/article/view/WV1472742561W57c844a16c025>
- [3] Hongfei Wu; Tiantian Mu; Hongjuan Ge; Yan Xing, Year: 2016, "Full-Range Soft-Switching-Isolated Buck-Boost Converters With Integrated Interleaved Boost Converter and Phase-Shifted Control", IEEE Transactions on Power Electronics, vol.31, no.2, pp.987-999.
- [4] Abdul Hakeem Memon ; Mazhar Hussain Baloach ; Anwar Ali Sahito, Year: 2018, "Achieving High Input PF for CRM Buck-Boost PFC Converter", IEEE Access, vol.6, pp.227-240.

- [5] Yangjun Lu ; Hongfei Wu ; Kai Sun ; Yan Xing, Year: 2016, "A Family of Isolated Buck-Boost Converters Based on Semiactive Rectifiers for High-Output Voltage Applications", *IEEE Transactions on Power Electronics*, vol.31,no.9,pp.6327-6340.
- [6] Hai Young Jung ; Sung Hwan Kim ; Byunghee Moon ; Seok-Hyun Lee, Year: 2018, "A New Circuit Design of Two-Switch Buck-Boost Converter", *IEEE Access*, vol.6,pp.47415-47423.
- [7] Mohamed O. Badawy ; Yilmaz Sozer ; J. Alexis De Abreu-Garcia, Year: 2016, "A Novel Control for a Cascaded Buck-Boost PFC Converter Operating in Discontinuous Capacitor Voltage Mode", *IEEE Transactions on Industrial Electronics*, vol.63 ,no.7,pp.4198-4210.
- [8] **Dr.M.Sangeetha**, M.Ruba , Gunavathi, B.Ragunathan, sasikumar,sivakumar , Dinesh(2023), "Automotive and Industrial Inverter Smart Grid Dc Ultra-Fast Charging Stations", *Semiconductor Optoelectronics*, Vol. 42 No. 2 (2023), 592-601 <https://bdtgd.cn/>, Vol. 42 No. 02(2023), 2023-11-15, <https://bdtgd.cn/article/view/2023/02-592.php>.
- [9] Niraj Rana ; Arnab Ghosh ; Subrata Banerjee, Year: 2018, "Development of an Improved Tristate Buck-Boost Converter With Optimized Type-3 Controller" *IEEE Journal of Emerging and Selected Topics in Power Electronics*, vol.6,no.1,pp.400-415.
- [10] Majid Abbasi ; Ahmad Afifi ; Mohamad Reza Alizadeh Pahlavani, Year: 2019, "Comments on "A Single-Inductor Multiple-Output Switcher With Simultaneous Buck, Boost, and Inverted Outputs", *IEEE Transactions on Power Electronics*, vol.34,no.2, pp.1980- 1984.
- [11] Naresh Kumar Miryala, Divit Gupta, "Data Security Challenges and Industry Trends" *IJARCCCE International Journal of Advanced Research in Computer and Communication Engineering*, vol. 11, no.11, pp. 300-309, 2022, Crossref <https://doi.org/10.17148/IJARCCCE.2022.111160>
- [12] Akhilandeswari, P., George, J.G. (2014). Secure Text Steganography. In: Sathiakumar, S., Awasthi, L., Masillamani, M., Sridhar, S. (eds) *Proceedings of International Conference on Internet Computing and Information Communications. Advances in Intelligent Systems and Computing*, vol 216. Springer, New Delhi.
- [13] Mallikarjunaradhya, V., Mistry, J., Ganesh, A., & Kiruthiga, T. (2023, August). The smart analysis of cell damage and cancerous prediction using information clustering model. In *2023 Second International Conference on Smart Technologies for Smart Nation (SmartTechCon)* (pp. 870-875). IEEE. | Google Scholar
- [14] Kushal Walia, 2024. "Scalable AI Models through Cloud Infrastructure" *ESP International Journal of Advancements in Computational Technology (ESP-IJACT)* Volume 2, Issue 2: 1-7. | Link
- [15] Muthukumaran Vaithianathan, Mahesh Patil, Shunye Frank Ng, Shiv Udkar, 2024. "Comparative Study of FPGA and GPU for High-Performance Computing and AI" *ESP International Journal of Advancements in Computational Technology (ESP-IJACT)* Volume 1, Issue 1: 37-46. [PDF]
- [16] Sridhar Selvaraj, 2024. "Futuristic SAP Fiori Dominance" *ESP International Journal of Advancements in Computational Technology (ESP-IJACT)* Volume 2, Issue 1: 32-37. | Google Scholar
- [17] Bhattacharya, S. (2024). Securing the Gatekeeper: Addressing Vulnerabilities in OAuth Implementations for Enhanced Web Security. *International Journal of Global Innovations and Solutions (IJGIS)*. <https://doi.org/10.21428/e90189c8.af381673>
- [18] Venkata Sathya Kumar Koppiseti, 2024. "The Future of Remote Collaboration: Leveraging AR and VR for Teamwork" *ESP International Journal of Advancements in Computational Technology (ESP-IJACT)* Volume 2, Issue 1: 56-65. [Link]
- [19] Sumanth Tatineni, Anirudh Mustyala, 2024. "Enhancing Financial Security: Data Science's Role in Risk Management and Fraud Detection" *ESP International Journal of Advancements in Computational Technology (ESP-IJACT)* Volume 2, Issue 2: 94-105.
- [20] Chanthati, S. R. (2024). Artificial Intelligence-Based Cloud Planning and Migration to Cut the Cost of Cloud. Sasibhushan Rao Chanthati. *American Journal of Smart Technology and Solutions*, 3(2), 13-24. <https://doi.org/10.54536/ajsts.v3i2.3210>
- [21] Arnab Dey, 2021. "Implementing Latest Technologies from Scratch: A Strategic Approach for Application Longevity" *European Journal of Advances in Engineering and Technology*, 2021, 8 (8): 22-26. | PDF
- [22] Dharmotharan Seenivasan, Muthukumaran Vaithianathan, 2023. "Real-Time Adaptation: Change Data Capture in Modern Computer Architecture" *ESP International Journal of Advancements in Computational Technology (ESP-IJACT)* Volume 1, Issue 2: 49-61
- [23] Shreyaskumar Patel "Enhancing Image Quality in Wireless Transmission through Compression and De-noising Filters" Published in *International Journal of Trend in Scientific Research and Development (ijtsrd)*, ISSN: 2456-6470, Volume-5 | Issue-3, April 2021, pp.1318-1323, URL: <https://www.ijtsrd.com/papers/ijtsrd41130.pdf>
- [24] Vijay Panwar, "AI-Powered Data Cleansing: Innovative Approaches for Ensuring Database Integrity and Accuracy," *International Journal of Computer Trends and Technology*, vol. 72, no. 4, pp. 116-122, 2024. Crossref, <https://doi.org/10.14445/22312803/IJCTT-V72I4P115>
- [25] Dixit, A.S., Patwardhan, A.V. and Pandit, A.B., 2021. PARAMETER OPTIMIZATION OF PRODIGIOSIN BASED DYE-SENSITIZED SOLAR CELL. *International Journal of Pharmaceutical, Chemical & Biological Sciences*, 11(1), pp.19-29.
- [26] Amit Mangal, 2021. "Evaluating Planning Strategies for Prioritizing the most viable Projects to Maximize Investment Returns" *ESP Journal of Engineering & Technology Advancements* 1(2): 69-77. [Link]

- [27] Chanthati, SasibhushanRao. (2021). Second Version on A Centralized Approach to Reducing Burnouts in the IT industry Using Work Pattern Monitoring Using Artificial Intelligence using MongoDB Atlas and Python. 10.13140/RG.2.2.12232.74249.
- [28] NileshCharankar, Dileep Kumar Pandiya, 2024, Title: Enhancing Efficiency and Scalability in Microservices Via Event Sourcing, INTERNATIONAL JOURNAL OF ENGINEERING RESEARCH & TECHNOLOGY (IJERT) Volume 13, Issue 04 (April 2024).
- [29] Empowering Rules Engines: AI and ML Enhancements in BRMS for Agile Business Strategies. (2022). International Journal of Sustainable Development through AI, ML and IoT, 1(2), 1-20. <https://ijsdai.com/index.php/IJSDAI/article/view/36>
- [30] S. E. V. S. Pillai and K. Polimetla, "Privacy-Preserving Network Traffic Analysis Using Homomorphic Encryption," 2024 International Conference on Integrated Circuits and Communication Systems (ICICACS), Raichur, India, 2024, pp. 1-6, doi: 10.1109/ICICACS60521.2024.10498523.
- [31] Chanthati, Sasibhushan Rao. (2021). How the Power of Machine – Machine Learning, Data Science and NLP Can Be Used to Prevent Spoofing and Reduce Financial Risks. 10.13140/RG.2.2.18761.76640.
- [32] PratikshaAgarwal, Arun Gupta, "Harnessing the Power of Enterprise Resource Planning (ERP) and Customer Relationship Management (CRM) Systems for Sustainable Business Practices," International Journal of Computer Trends and Technology, vol. 72, no. 4, pp. 102-110, 2024. Crossref, <https://doi.org/10.14445/22312803/IJCTT-V72I4P113>
- [33] Borra, Praveen; The Transformative Role of Microsoft Azure AI in Healthcare International Journal of Emerging Trends in Engineering Research 12 7, 108-113, 2024, WARSE.
- [34] Shreyaskumar Patel "Enhancing Image Quality in Wireless Transmission through Compression and De-noising Filters" Published in International Journal of Trend in Scientific Research and Development (ijtsrd), ISSN: 2456-6470, Volume-5 | Issue-3, April 2021, pp.1318-1323, URL: <https://www.ijtsrd.com/papers/ijtsrd41130.pdf>
- [35] CHANDRASEKARAN, A. and KALLA, D. (2023) Heart disease prediction using chi-square test and linear regression. Computer Science & Information Technology, 13, pp. 135-146.
- [36] Palakurti, N. R., &Kolasani, S. (2024). AI-Driven Modeling: From Concept to Implementation. In Practical Applications of Data Processing, Algorithms, and Modeling (pp. 57-70). IGI Global.
- [37] S. Duary, P. Choudhury, S. Mishra, V. Sharma, D. D. Rao and A. Paul Aderemi, "Cybersecurity Threats Detection in Intelligent Networks using Predictive Analytics Approaches," 2024 4th International Conference on Innovative Practices in Technology and Management (ICIPTM), Noida, India, 2024, pp. 1-5, doi: 10.1109/ICIPTM59628.2024.10563348.
- [38] VenkataSathya Kumar Koppiseti, 2024. "Deep Learning: Advancements and Applications in Artificial Intelligence" ESP International Journal of Advancements in Computational Technology (ESP-IJACT) Volume 2, Issue 2: 106-113. [Link]
- [39] Komperla, R. C., Pokkuluri, K. S., Nomula, V. K., Gowri, G. U., Rajest, S. S., &Rahila, J. (2024). Revolutionizing Biometrics With AI-Enhanced X-Ray and MRI Analysis. In P. Paramasivan, S. Rajest, K. Chinnusamy, R. Regin, & F. John Joseph (Eds.), Advancements in Clinical Medicine (pp. 1-16). IGI Global. <https://doi.org/10.4018/979-8-3693-5946-4.ch001>
- [40] Naga Ramesh Palakurti, 2022. "AI Applications in Food Safety and Quality Control" ESP Journal of Engineering & Technology Advancements 2(3): 48-61. [PDF].
- [41] Katragadda, V. . (2024). Leveraging Intent Detection and Generative AI for Enhanced Customer Support. Journal of Artificial Intelligence General Science (JAIGS) ISSN:3006-4023, 5(1), 109-114. <https://doi.org/10.60087/jaigs.v5i1.178>.
- [42] Praveen Borra, Comparison and Analysis of Leading Cloud Service Providers (AWS, Azure and GCP), International Journal of Advanced Research in Engineering and Technology (IJARET), 15(3), 2024, pp. 266- 278.
- [43] Chanthati, S. R. (2024). Artificial Intelligence-Based Cloud Planning and Migration to Cut the Cost of Cloud Sasibhushan Rao Chanthati. American Journal of Smart Technology and Solutions, 3(2), 13-24. <https://doi.org/10.54536/ajsts.v3i2.3210>.
- [44] Artificial Intelligence-Based Cloud Planning and Migration to Cut the Cost of Cloud SR Chanthati - Authorea Preprints, 2024 <http://dx.doi.org/10.22541/au.172115306.64736660/v1> Sasi-Rao: SR Chanthati will pick up the Google scholar and Chanthati, S. R. (2024).
- [45] Avani Dave. (2021). Trusted Building Blocks for Resilient Embedded Systems Design.University of Maryland.
- [46] Bhattacharya, S., Najana, M., Deshmukh, G., & Dhaliwal, A. S. (2024). Virtual AI Agents in Registration Systems: Enhancing Security and Usability Across Industries. International Journal of Global Innovations and Solutions (IJGIS). <https://doi.org/10.21428/e90189c8.9a033ba9>
- [47] Chanthati, S. R. (2024). Website Visitor Analysis & Branding Quality Measurement Using Artificial Intelligence. Sasibhushan Rao Chanthati. <https://journals.e-palli.com/home/index.php/ajet>. <https://doi.org/10.54536/ajet.v3i3.3212>
- [48] Kumar Shukla, Shashikant Tank, 2024. "CYBERSECURITY MEASURES FOR SAFEGUARDING INFRASTRUCTURE FROM RANSOMWARE AND EMERGING THREATS", International Journal of Emerging Technologies and Innovative Research (www.jetir.org), ISSN: 2349-5162, Vol.11, Issue 5, page no.i229-i235, May-2024, Available: <http://www.jetir.org/papers/IETIR2405830.pdf>
- [49] Jacopo Pianigiani, Manish Krishnan, Anantharamu Suryanarayana, Vivekananda Shenoy, 2020. Cloud Network Having Multiple Protocols Using Virtualization Overlays across Physical and Virtualized Workloads, US10880210B2. [Link]

- [50] Shashikant Tank, Kumar Shukla, 2024."A COMPARATIVE ANALYSIS OF NVMe SSD CLASSIFICATION TECHNIQUES", International Journal of Emerging Technologies and Innovative Research (www.jetir.org), ISSN: 2349-5162, Vol.11, Issue 5, page no.c261-c266, May-2024, Available : <http://www.jetir.org/papers/JETIR2405231.pdf>
- [51] Chandrakanth Lekkala (2023) Deploying and Managing Containerized Data Workloads on Amazon EKS. Journal of Artificial Intelligence & Cloud Computing. SRC/JAICC-342. DOI: doi.org/10.47363/JAICC/2023 (2)324.
- [52] Patel, N. (2024, March). SECURE ACCESS SERVICE EDGE(SASE): "EVALUATING THE IMPACT OF CONVERGED NETWORK SECURITYARCHITECTURES IN CLOUD COMPUTING." Journal of Emerging Technologies and Innovative Research. <https://www.jetir.org/papers/JETIR2403481.pdf>
- [53] Ayyalasomayajula, Madan Mohan Tito, Sathishkumar Chintala, and Sandeep Reddy Narani. "Optimizing Textile Manufacturing With Neural Network Decision Support: An Ornstein-Uhlenbeck Reinforcement Learning Approach." Journal of Namibian Studies: History Politics Culture 35 (2023): 335-358.
- [54] Vishwanath Gojanur , Aparna Bhat, "Wireless Personal Health Monitoring System", IJETCAS:International Journal of Emerging Technologies in Computational and Applied Sciences,eISSN: 2279-0055,pISSN: 2279-0047, 2014. [Link]
- [55] Ayyalasomayajula, Madan Mohan Tito, et al. "Proactive Scaling Strategies for Cost-Efficient Hyperparameter Optimization in Cloud-Based Machine Learning Models: A Comprehensive Review." ESP Journal of Engineering & Technology Advancements (ESP JETA) 1.2 (2021): 42-56.
- [56] Mistry, H., Shukla, K., & Patel, N. (2024). Transforming Incident Responses, Automating Security Measures, and Revolutionizing Defence Strategies through AI-Powered Cybersecurity. Journal of Emerging Technologies and Innovative Research, 11(3), 25. <https://www.jetir.org/>
- [57] Ayyalasomayajula, M., & Chintala, S. (2020). Fast Parallelizable Cassava Plant Disease Detection using Ensemble Learning with Fine Tuned AmoebaNet and ResNeXt-101. Turkish Journal of Computer and Mathematics Education (TURCOMAT), 11(3), 3013-3023.
- [58] Aparna Bhat, "Comparison of Clustering Algorithms and Clustering Protocols in Heterogeneous Wireless Sensor Networks: A Survey," 2014 INTERNATIONAL JOURNAL OF SCIENTIFIC PROGRESS AND RESEARCH (IJSPR)-ISSN : 2349-4689 Volume 04- NO.1, 2014. [Link]
- [59] Ayyalasomayajula, Madan Mohan Tito, et al. "Implementing Convolutional Neural Networks for Automated Disease Diagnosis in Telemedicine." 2024 Third International Conference on Distributed Computing and Electrical Circuits and Electronics (ICDCECE). IEEE, 2024.
- [60] Shashikant Tank Kumar Mahendrabhai Shukla, Nimeshkumar Patel, Veeral Patel, 2024." AI BASED CYBER SECURITY DATA ANALYTIC DEVICE", 414425-001, [Link]
- [61] Ayyalasomayajula, Madan Mohan Tito, Akshay Agarwal, and Shahnawaz Khan. "Reddit social media text analysis for depression prediction: using logistic regression with enhanced term frequency-inverse document frequency features." International Journal of Electrical and Computer Engineering (IJECE) 14.5 (2024): 5998-6005.
- [62] Aparna Bhat, Rajeshwari Hegde, "Comprehensive Study of Renewable Energy Resources and Present Scenario in India," 2015 IEEE International Conference on Engineering and Technology (ICETECH), Coimbatore, TN, India, 2015. [Link]
- [63] Ayyalasomayajula, Madan Mohan Tito. "Innovative Water Quality Prediction For Efficient Management Using Ensemble Learning." Educational Administration: Theory and Practice 29.4 (2023): 2374-2381.
- [64] Sarangkumar Radadia Kumar Mahendrabhai Shukla ,Nimeshkumar Patel ,Hirenkumar Mistry,Keyur Dodiya 2024." CYBER SECURITY DETECTING AND ALERTING DEVICE", 412409-001, [Link]
- [65] Ayyalasomayajula, Madan Mohan Tito, Srikrishna Ayyalasomayajula, and Sailaja Ayyalasomayajula. "Efficient Dental X-Ray Bone Loss Classification: Ensemble Learning With Fine-Tuned VIT-G/14 And Coatnet-7 For Detecting Localized Vs. Generalized Depleted Alveolar Bone." Educational Administration: Theory and Practice 28.02 (2022).
- [66] Aparna K Bhat, Rajeshwari Hegde, 2014. "Comprehensive Analysis Of Acoustic Echo Cancellation Algorithms On DSP Processor", International Journal of Advance Computational Engineering and Networking (IJACEN), volume 2, Issue 9, pp.6-11. [Link]
- [67] Ayyalasomayajula, M. M. T., Chintala, S., & Sailaja, A. (2019). A Cost-Effective Analysis of Machine Learning Workloads in Public Clouds: Is AutoML Always Worth Using? International Journal of Computer Science Trends and Technology (IJCST), 7(5), 107-115.
- [68] Nimeshkumar Patel, 2022." QUANTUM CRYPTOGRAPHY IN HEALTHCARE INFORMATION SYSTEMS: ENHANCING SECURITY IN MEDICAL DATA STORAGE AND COMMUNICATION", Journal of Emerging Technologies and Innovative Research, volume 9, issue 8, pp.g193-g202. [Link]
- [69] Bhat, A., & Gojanur, V. (2015). Evolution Of 4g: A Study. International Journal of Innovative Research in Computer Science & Engineering (IJRCSE). Booth, K. (2020, December 4). How 5G is breaking new ground in the construction industry. BDC Magazine.<https://bdcmagazine.com/2020/12/how-5g-is-breaking-new-ground-in-the-constructionindustry/>. [Link]
- [70] Nimeshkumar Patel, 2021." SUSTAINABLE SMART CITIES: LEVERAGING IOT AND DATA ANALYTICS FOR ENERGY EFFICIENCY AND URBAN DEVELOPMENT", Journal of Emerging Technologies and Innovative Research, volume 8, Issue 3, pp.313-319. [Link]
- [71] Bhat, A., Gojanur, V., & Hegde, R. (2014). 5G evolution and need: A study. In International conference on electrical, electronics, signals, communication and optimization (EESCO) – 2015.[Link]

- [72] Chintala, S. ., & Ayyalasomayajula, M. M. T. . (2019). OPTIMIZING PREDICTIVE ACCURACY WITH GRADIENT BOOSTED TREES IN FINANCIAL FORECASTING. *Turkish Journal of Computer and Mathematics Education (TURCOMAT)*, 10(3), 1710-1721. <https://doi.org/10.61841/turcomat.v10i3.14707>
- [73] A. Bhat, V. Gojanur, and R. Hegde. 2015. 4G protocol and architecture for BYOD over Cloud Computing. In *Communications and Signal Processing (ICCSP), 2015 International Conference on*. 0308-0313. Google Scholar. [Link]
- [74] M. Hindka, "Securing the Digital Backbone: An In-depth Insights into API Security Patterns and Practices", *Computer Science and Engineering*, Vol. 14, No. 2, pp. 35-41, 2024.
- [75] M. Hindka, "Design and Analysis of Cyber Security Capability Maturity Model", *International Research Journal of Modernization in Engineering Technology and Science*, Vol. 6, No. 3, pp. 1706-1710, 2024.
- [76] Hindka, M. (2024, June). Optimization Accuracy of Secured Cloud Systems Using Deep Learning Model. In *2023 4th International Conference on Intelligent Technologies (CONIT)* (pp. 1-5). IEEE.
- [77] Ankitkumar Tejani, Harsh Gajjar, Vinay Toshniwal, Rashi Kandelwal, 2022. "The Impact of Low-GWP Refrigerants on Environmental Sustainability: An Examination of Recent Advances in Refrigeration Systems" *ESP Journal of Engineering & Technology Advancements* 2(2): 62-77. [Link]
- [78] Ankitkumar Tejani, Jyoti Yadav, Vinay Toshniwal, Harsha Gajjar, 2022. "Natural Refrigerants in the Future of Refrigeration: Strategies for Eco-Friendly Cooling Transitions", *ESP Journal of Engineering & Technology Advancements*, 2(1): 80-91. [Link]
- [79] Mihir Mehta, 2024," *A Comparative Study Of AI Code Bots: Efficiency, Features, And Use Cases*", *International Journal of Science and Research Archive*, volume 13, Issue 1, 595-602, [Link]
- [80] Dhameliya, N. (2022). Power Electronics Innovations: Improving Efficiency and Sustainability in Energy Systems. *Asia Pacific Journal of Energy and Environment*, 9(2), 71-80. [Link]
- [81] Vikramraj Kumar Thiyagarajan, 2024. "Financial Transformation: Redefining Consolidation Processes with Oracle FCCS", *International Journal of Innovative Research of science, Engineering and technology (IJIRSET)*, Volume 13, Issue 9, [Link]
- [82] Vedamurthy Gejjegondanahalli Yogeshappa, 2024. "AI-Driven Precision Medicine: Revolutionizing Personalized Treatment Plans", *International Journal of Computer Engineering and Technology (IJCET)*, 15(5), 2024, pp. 455-474. [Link]
- [83] Sunil Kumar Suvvari. (2020). The Impact of Agile on Customer Satisfaction and Business Value. *Innovative Research Thoughts*, 6(5), 199-211. <https://doi.org/10.36676/irt.v6.i5.1413>
- [84] Sunil Kumar Suvvari. (2019). An Exploration of Agile Scaling Frameworks: Scaled Agile Framework (Safe), Large-Scale Scrum (Less), and Disciplined Agile Delivery (DAD). *International Journal on Recent and Innovation Trends in Computing and Communication*, 7(12), 9-17. Retrieved from <https://www.ijritcc.org/index.php/ijritcc/article/view/10759>
- [85] Sunil Kumar Suvvari, Anjum, B., & Hussain, M. (2020). Key Factors Impacting the E-learning Effectiveness for Computer Science Students: An Empirical Study. *Webology*, 17(4), 837-847. Retrieved from [https://www.webology.org/data-cms/articles/20240628011520pmWEBOLOGY%2017%20\(4\)%20-%2076.pdf](https://www.webology.org/data-cms/articles/20240628011520pmWEBOLOGY%2017%20(4)%20-%2076.pdf)