

Original Article

# Sound Bite Hearing System Embed with OCR Techniques for Blind and Deaf People

P.Kavitha<sup>1</sup>, T. Ashok<sup>2</sup>, M. Parameswari<sup>3</sup>

<sup>1</sup>Dept. of ECE, MAM School of Engineering, Tamilnadu, India

<sup>2</sup>College of BME, Kongunadu Engineering, Tamilnadu, India

<sup>3</sup>College of BME, Dhanalakshmi Srinivasan Engineering College, Tamilnadu, India

**Abstract:** Speech and text serve as primary mediums for human communication. While sight is typically necessary to access textual information, individuals with visual impairments can rely on auditory input. This paper proposes a system that utilizes a headset as an interface between the user and the system. Optical Character Recognition (OCR) technology is employed to recognize characters, which are then vocalized through the headset. The system includes a camera mounted on spectacles or a head device to capture the entire paper under favorable lighting conditions. The paper's content must be in English and presented in a legible font size. When all requirements are met, the system captures an image, processes it, and if successful, announces via Bluetooth headset that the content has been recognized. Subsequently, the system vocalizes the converted text, enabling blind individuals to access written materials independently. This proposed PC-based reader offers a solution for blind individuals to access written content without relying on human assistance.

**Keywords:** Optical Character Recognitions, Visual Impairment, Voice Processing Module.

## INTRODUCTION

The World Health Organisation (WHO) estimates that there are 45 million blind persons in the world and 285 million visually impaired people worldwide, 90% of who live in poor nations. Although there are already solutions available to help blind people read, none of them provide a reading experience that is similar to that of sighted people. For the blind community, a portable text reader that is both easily available and reasonably priced is desperately needed.

In our society, information is predominantly available in written form, which is easily accessible to sighted individuals. However, for blind or visually impaired individuals, accessing information presents a significant challenge. Traditional methods of information dissemination, such as printed books, are inaccessible to them. Therefore, there is a need for a solution that can convert written information into a format that blind individuals can easily access.

One solution is to introduce a smart device equipped with a multimodal system capable of converting documents into formats interpretable by the blind. The "Blind Reader" is designed for touch devices and offers a user-friendly and interactive system for blind or low-vision individuals. Users can tap on words, which are then audibly presented through a text-to-speech engine. This system is particularly beneficial in scenarios like medicine identification, where blind individuals may struggle to determine whether they have correctly identified a medication. With a mobile application, the solution becomes easily accessible, requiring minimal hardware.

The suggested system uses Open Computer Vision (Open CV), a set of image processing capabilities, to recognise text. Applying mathematical processes to photographs in order to extract information is known as image processing. It has several uses, such as text recognition, facial recognition, and computer graphics. Text recognition is affected by a number of factors, including background, alignment, font size, and font type. Licence plate recognition is an example of text recognition that shows the adaptability of image processing methods.

## PROBLEM STATEMENT

With over 40 million visually impaired individuals living there, India is home to the greatest percentage of blind persons worldwide (20%). Furthermore, over 90% of these individuals have little to no access to the



assistive devices that they require. For those who are blind or visually impaired, independent travel is a well-known issue. Additionally, the availability of affordable, high-performing, and portable digital imaging devices is growing. The primary means of human communication are speech and written language. For someone to access the content in a text, they must have vision. On the other hand, people with low vision can still discern information from noise. It can identify text from any document, identify names on signs, and identify names on medications and textbooks. To efficiently extract and identify text from scene photos using computer vision technology, and to translate the identified text into speech so that it may be integrated with hardware to create an electronic travel assistance for the blind. This system uses OCR with the Sound bite hearing technology to produce audio output for the blind and deaf.

### **EXISTING SYSTEM**

The current project makes use of a camera-based technology that allows users to read text documents. The framework focuses on integrating an image-capturing method into a MATLAB-based software system. The majority of blind individuals read books and papers in Braille, which is more difficult to produce and less accessible. This makes it necessary to enhance the tools that could alleviate the agonising chores that blind individuals must perform from start to finish. Following analysis, a Python-based TTS (text to speech) conversion unit integrated inside the Raspberry Pi converts text to speech. Lastly, the audio amplifier receives the audio output so that it may be read out. One of the main issues with this approach is how hard it is to make all of the books and documents accessible to blind individuals.

### **PROPOSED SYSTEM**

The proposed system offers two modes of operation catering to both visually impaired and hearing impaired individuals. For visually impaired users, the system comprises two main modules: the image processing module and the voice processing module. In the image processing module, an image is captured using a camera and then converted into text format. Optical Character Recognition (OCR) plays a pivotal role in this module. OCR technology automatically recognizes characters through optical means, simulating the human sense of sight. Prior to feeding the image to the OCR system, it undergoes conversion to a binary image to enhance recognition accuracy.

The voice processing module is responsible for converting the text obtained from the image processing module into audible sound. This transformation ensures that the sound produced possesses specific characteristics to aid comprehension by the user. Essentially, the system first converts the captured image (in .jpg format) into text (.txt format) using OCR. Subsequently, the text is converted into speech, allowing visually impaired users to access information effectively.

Using a camera-based assistive text reader, the suggested approach seeks to help blind people see text labels, printed notes, and product information. The system reads text from images taken by a camera mounted on spectacles using optical character recognition (OCR) technology. After the text has been recognised, a speech algorithm is used to turn it into voice output.

In order to put this concept into practice, a real-time prototype that worked with a camera, PC, and ESP 8266-12E NODE MCU controller was created. The system records frames and checks to see if any text is present. The image is processed in multiple stages once it is captured: it is first turned into grayscale and then filtered with a Gaussian filter to cut down on noise. Adaptive Gaussian thresholding is used to lower noise and improve image quality even further. These preparatory procedures enhance the precision of OCR's text recognition.

Top of FormAfter the binary conversion, the filtered image is cropped to eliminate character-free regions. After cropping the frame, text recognition is performed using Tesseract OCR. The OCR produces a text file as its output, which the e-Speak text-to-speech synthesis system uses as input.e-Speak creates an audio output by converting the text file into an analogue signal. The user can then hear this signal by donning headphones. A complete solution is put into place for people who are deaf or hard of hearing. It combines a sound bite hearing device, text-to-speech synthesis (TTS), and optical character recognition (OCR).

### BLOCK DIAGRAM

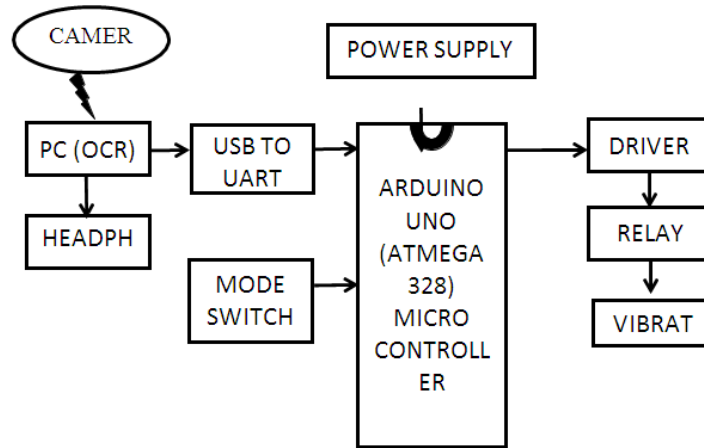

Figure 1: Block Diagram

In this integrated system, blind and deaf individuals can receive audio output through a vibration motor. The sound bite hearing system processes sound and wirelessly transmits sound signals through the teeth, enabling both blind and deaf individuals to perceive auditory information. This holistic approach ensures accessibility for individuals with visual and hearing impairments.

An alternative to surgical bone conduction implants, which must be surgically implanted into the skull in order to conduct sound, is the sound bite sensor. The sound bite sensor uses the teeth rather than an implanted part, therefore surgery is not required. For those who might encounter distortion with traditional hearing aids that only enhance sound, this novel technique is especially helpful.

In the instance of bone conduction, sound waves pass through bones and into the inner ear. Sound vibrations flow through media. Sound waves vibrate the skull's bones when they enter the head. The temporal and frontal bones, as well as the jaw and soft tissue, are some of the routes by which these vibrations can subsequently reach the inner ear. Through this approach, people can hear without depending on the conventional method of hearing through the middle ear and ear canal.

The device receives signals from a speaker and converts them into sound vibrations. These vibrations, though initially strong, are amplified to ensure they are picked up by the cochlea with the assistance of an amplifier, driver relay circuit, and vibrator. This process allows sound to be transported from the impaired ear directly to the hearing ear.

This hearing device is designed to be fitted to the upper left or right teeth at the back of the mouth. Importantly, it doesn't require any alteration to the user's teeth, and it can be easily inserted and removed as needed. The device itself is a flat piece, contained within a sealed rechargeable battery, and incorporates electronics and wireless capabilities to pick up sound transmissions from a behind-the-ear microphone.

This system's portability is a key feature, allowing users to carry the device with them anywhere and use it at any time. This flexibility ensures that individuals with hearing impairments can access sound enhancement whenever they need it, contributing to their overall quality of life and communication abilities.

#### Optic Character Identification:

The electronic or mechanical process of turning images containing printed, handwritten, or typed text into machine-encoded text is known as optical character recognition, or OCR. Sources for this conversion can include scanned documents, images of documents, and scenes photographed, including text on billboards and signage in

landscape photography. OCR is a major field of study in computer vision, artificial intelligence, and pattern recognition that aims to create methods and algorithms that can reliably extract and interpret text from visual inputs.



### Tesseractocr:

Under the Apache 2.0 licence, Tesseract is a potent open-source text recognition (OCR) engine. For developers, it provides an API to extract printed text from photos in addition to direct usage. Tesseract can handle text in a variety of languages thanks to its broad language support. Although Tesseract does not come with a built-in graphical user interface (GUI), there are plenty of third-party solutions that can be used. Furthermore, Tesseract may be used with a variety of frameworks and computer languages by means of wrappers, which are available from its repository.

### OCR With Pytesseract and Open CV:

PyTesseract is a wrapper for Tesseract-OCR Engine. It is also useful as a stand-alone invocation script to Tesseract, a script can read all image types supported by the Pillow and Leetonia imaging libraries, including jpeg, png, gif, bmp, tiff, and others. More info about Python approach read here. The code for this tutorial can be found in this repository MOIHy.

### WORKING

As seen in the above illustration, the shell and spring assembly makes mobile contact with the fixed contact points beneath it. Only one stationary contact in this switch has its pin soldered, leaving the other without a rotor. Combinations of switch On and Off states can be achieved when all three contacts are used. Depending on what the default state indicates, this one functions as an ON-OFF or OFF-ON switch. Slide switches are often made to operate on home voltages between 220 and 240 volts, however for optimal results and to prevent unintended side effects; it is common to consult their design ratings. Because there are no tiny wires that could break off and impair operation, the parts utilized in the switch are highly sturdy. An assortment of slides witches known as the DIP switches are utilized in devices that need more switches.

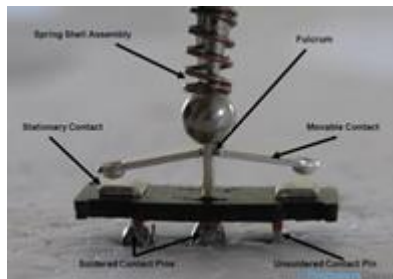

The switch with two of the three contacts soldered is seen above. The default position is when the movable contact plate's spring-shell assembly is at its pivot. This is the switch's default state, and it is typically taken as an off position. There is no contact between the stationary and moveable contacts when the shell is positioned at the fulcrum. At this resting posture, the spring is in its coiled state and is unable to release because the fulcrum is fixed in place. The shell is moved from the top of the full crab to either side of these e-saws as the movers move

towards either of the contacts. Because it is moveable, the spring can decompress and force the tal shell firmly against the saw, which is then pushed downward.

#### **ESP-12E Module:**

The ESP-12E module, which contains the ESP8266 chip, is a feature of the development board. The 32-bit LX106 RISC CPU from TensilicaXtensa®, which can run at a clock frequency of 80 to 160 MHz, is found on this chip. Additionally, it has 4 MB of Flash memory and 128 KB of RAM, which are enough for managing lengthy strings that are frequently encountered in web pages, JSON/XML data, and other applications for IoT devices.

The ESP8266 chip integrates an 802.11b/g/n HT40 Wi-Fi transceiver, enabling it to connect to Wi-Fi networks, access the Internet, and establish its own network for direct device connections. This versatility enhances its capabilities for various IoT applications. In terms of audio processing, a coil, often referred to as a voice coil, carries the current generated by the audio source. This current represents the audio signal and needs to be converted from an electrical signal into a series of audio vibrations. The electrical signal flowing through the voice coil fluctuates in accordance with the required audio vibrations.

The voice coil is situated within a cylindrical cutaway in the magnetic structure, ensuring it remains suspended without contacting the sides during normal operation. The current flowing through the voice coil generates its own magnetic field, which interacts with the fixed magnet's magnetic field. This interaction creates forces that cause the coil to move slightly in and out of the magnetic field in alignment with the current flow. The underlying principle behind this operation is electromagnetic induction, which is also employed in various other devices such as electric motors, relays, and bells. This mechanism enables the conversion of electrical signals into mechanical motion, resulting in the production of sound

#### **Top of Form:**

The motion of the voice coil is transmitted to the diaphragm, which in turn moves a larger volume of air, making the vibrations audible. Due to the compact size of earphones or headphones, they do not require suspension materials typically found in larger loudspeakers. The diaphragm itself is sturdy enough to maintain the necessary alignment with the magnet without touching.

In earphones and headphones, the voice coil is typically small, and the wire used is relatively thin since the current levels required are much lower compared to those needed for loudspeakers. Thin wires connect the voice coil to the back of the earphone, facilitating easy entry of the electrical signal into the earphone assembly. The arrangement of these connections is critical to the headphone's performance, as any impediment to movement can significantly impact its operation.

### **CONCLUSION**

This study presents an intelligent Python-based text reader that can effectively translate text from photos to speech. The tool provides a portable and affordable way to turn text from images to voice. By adopting certain image processing techniques, the Tesseract OCR engine produces better text recognition accuracy by improving the quality of the original image. With 99% accuracy, the resultant text conversion is quite accurate.

Furthermore, the converted text is transformed into an audio file using a Python-based TTS (Text-to-Speech) synthesizer, ensuring a natural and pleasant audio output. The device guarantees high precision and consistency in its performance. Currently, it supports the English language, but future research could focus on making it multilingual to cater to different languages. Additionally, potential enhancements may include features like voice modulation and alerts for poor-quality image capture.

The goal of this project, "Reader for Blind," is to encourage independence and give blind people more control over their daily life. Reading printed text from pamphlets, books, periodicals, and other materials is just one of the many responsibilities it covers. Users can independently access daily information, such as newspapers, with this device. In addition, the concept includes a sound bite hearing device that will help people who are deaf or blind.

The goal of this all-encompassing strategy is to enhance the quality of life and accessibility for those who have sensory impairments.

## REFERENCES

- [1] Pandian, A. P. (2019), "Artificial Intelligence Application in Smart Warehousing Environment For Automated Logistics", *Journal of Artificial Intelligence*, 1(02), 63-72.
- [2] Nirmal, D. "Artificial Intelligence Based Distribution System Management and Control." *Journal of Electronics* 2, no. 02 (2020): 137-147.
- [3] Amjed S. Al-Fahoum, Heba B. Al-Hmoud, and Ausaila A. Al-Fraihat, "A Smart Infrared Microcontroller-Based Blind Guidance System," *Active and Passive Electronic Components*, vol. 2013, p. 7, 2013.
- [4] Velázquez R. (2010) *Wearable Assistive Devices for the Blind*. In: Lay-Ekuakille A., Mukhopadhyay S.C. (eds) *Wearable and Autonomous Biomedical Devices and Systems for Smart Environment*. Lecture Notes in Electrical Engineering, vol 75. Springer, Berlin, Heidelberg.
- [5] Manduchi R. (2012) *Mobile Vision as Assistive Technology for the Blind: An Experimental Study*. In: Miesenberger K., Karshmer A., Penaz P., Zagler W. (eds) *Computers Helping People with Special Needs*. ICCHP 2012. Lecture Notes in Computer Science, vol 7383. Springer, Berlin, Heidelberg.
- [6] Mallikarjunaradhya, V., Mistry, J., Ganesh, A., & Kiruthiga, T. (2023, August). The smart analysis of cell damage and cancerous prediction using information clustering model. In *2023 Second International Conference on Smart Technologies for Smart Nation (SmartTechCon)* (pp. 870-875). IEEE. | [Google Scholar](#)
- [7] Ms. Kavya S., Ms. Swathi, Mrs. Mimitha Shetty, 2019, Assistance System for Visually Impaired using AI, *INTERNATIONAL JOURNAL OF ENGINEERING RESEARCH & TECHNOLOGY (IJERT)* RTESIT- 2019 (VOLUME 7- ISSUE 08).
- [8] A. Nishajith, J. Nivedha, S. S. Nair and J. Mohammed Shaffi, "Smart Cap - Wearable Visual Guidance System for Blind," *2018 International Conference on Inventive Research in Computing Applications (ICIRCA)*, Coimbatore, 2018, pp. 275-278, doi:10.1109/ICIRCA.2018.8597327.
- [9] Sarfraz, M., Constantinescu, A., Zujej, M. et al. A Multimodal Assistive System for Helping Visually Impaired in Social Interactions. *Informatik Spektrum* 40, 540-545 (2017), <https://doi.org/10.1007/s00287-017-1077-7>
- [10] "WLU6331 WiFi Adapter RF Exposure Info (SAR) Raspberry Pi Trading" Dec. 24, 2014. Accessed on: Aug. 1, 2020. [Online]. Available: <https://fccid.io/2ABCB-WLU6331/RF-Exposure-Info/RFExposure-Info-SAR-pdf-2489354>
- [11] P. Viola and M. Jones, "Rapid object detection using a boosted cascade of simple features," *Proceedings of the 2001 IEEE Computer Society Conference on Computer Vision and Pattern Recognition*. CVPR 2001, Kauai, HI, USA, 2001, pp. I-1, doi:10.1109/CVPR.2001.990517.
- [12] Z. Wei, Y. Sun, J. Wang, H. Lai and S. Liu, "Learning Adaptive Receptive Fields for Deep Image Parsing Network," *2017 IEEE Conference on Computer Vision and Pattern Recognition (CVPR)*, Honolulu, HI, 2017, pp. 3947-3955, doi:10.1109/CVPR.2017.420.
- [13] Chanthati, S. R. (2024). Artificial Intelligence-Based Cloud Planning and Migration to Cut the Cost of Cloud. *Sasibhushan Rao Chanthati. American Journal of Smart Technology and Solutions*, 3(2), 13-24. <https://doi.org/10.54536/ajsts.v3i2.3210>
- [14] Davis E. King. Dlib-ml: A machine learning toolkit. *Journal of Machine Learning Research*, 10:1755-1758, 2009.
- [15] N. Dalal and B. Triggs, "Histogram of oriented gradients for human detection," *2005 IEEE Computer Society Conference on Computer Vision and Pattern Recognition (CVPR'05)*, San Diego, CA, USA, 2005, pp. 886-893 vol. 1, doi:10.1109/CVPR.2005.177.
- [16] Naresh Kumar Miryala, Divit Gupta, "Big Data Analytics in Cloud - Comparative Study," *International Journal of Computer Trends and Technology*, vol. 71, no. 12, pp. 30-34, 2023. Crossref, <https://doi.org/10.14445/22312803/IJCTT-V71I12P107>
- [17] Jabin Geevarghese George (2024). Leveraging Enterprise Agile and Platform Modernization in the Fintech AI Revolution: A Path to Harmonized Data and Infrastructure, *International Research Journal of Modernization in Engineering Technology and Science*, Volume 6, Issue 4: 88-94
- [18] Jinal Mistry, Ashween Ganesh, Rakesh Ramakrishnan, J. Logeshwaran. (2023, August). IoT based congenital heart disease prediction system to amplify the authentication and data security using cloud computing. *European Chemical Bulletin*, 12(S3), 7201-7213 | [Google Scholar](#)
- [19] Kushal Walia, 2024. "Scalable AI Models through Cloud Infrastructure" *ESP International Journal of Advancements in Computational Technology (ESP-IJACT)* Volume 2, Issue 2: 1-7. | [Link](#)
- [20] Muthu kumaran Vaithianathan, Mahesh Patil, Shunye Frank Ng, Shiv Udgar, 2024. "Energy-Efficient FPGA Design for Wearable and Implantable Devices" *ESP International Journal of Advancements in Science & Technology (ESP-IJAST)* Volume 2, Issue 2: 37-51. [PDF]
- [21] Sridhar Selvaraj, 2024. "SAP Supply Chain with Industry 4.0" *ESP International Journal of Advancements in Computational Technology (ESP-IJACT)* Volume 2, Issue 1: 44-48. | [Google Scholar](#)

- [22] "reGIFCAPTCHA: Revolutionizing User Interaction and Security in CAPTCHA Technology", International Journal of Emerging Technologies and Innovative Research ([www.jetir.org](http://www.jetir.org)), ISSN:2349-5162, Vol.10, Issue 12, page no.d891-d893, December-2023, Available: <http://www.jetir.org/papers/JETIR2312398.pdf>
- [23] Venkata Sathya Kumar Koppiseti, 2024. "The Role of Explainable AI in Building Trustworthy Machine Learning Systems" *ESP International Journal of Advancements in Science & Technology (ESP-IJAST)* Volume 2, Issue 2: 16-21. [Link]
- [24] Sumanth Tatineni, Anirudh Mustyala, 2024. "Leveraging AI for Predictive Upkeep: Optimizing Operational Efficiency" *ESP International Journal of Advancements in Computational Technology (ESP-IJACT)* Volume 2, Issue 1: 66-79.
- [25] Arnab Dey (2022) Automation for CI/CD Pipeline for Code Delivery with Multiple Technologies. *Journal of Mathematical & Computer Applications*. SRC/JMCA-170. DOI: [doi.org/10.47363/JMCA/2022\(1\)138](https://doi.org/10.47363/JMCA/2022(1)138)
- [26] Dharmotharan Seenivasan, "Improving the Performance of the ETL Jobs," *International Journal of Computer Trends and Technology*, vol. 71, no. 3, pp. 27-33, 2023. Crossref, <https://doi.org/10.14445/22312803/IJCTT-V71I3P105>
- [27] "Optimizing Wiring Harness Minimization through Integration of Internet of Vehicles (IOV) and Internet of Things (IoT) with ESP-32 Module: A Schematic Circuit Approach", *International Journal of Science & Engineering Development Research* ([www.ijrti.org](http://www.ijrti.org)), ISSN:2455-2631, Vol.8, Issue 9, page no.95 - 103, September-2023, Available : <http://www.ijrti.org/papers/IJRTI2309015.pdf>
- [28] Panwar, V. (2024). Optimizing Big Data Processing in SQL Server through Advanced Utilization of Stored Procedures. *Journal Homepage*: <http://www.ijmra.us>, 14(02).
- [29] Dixit, A.S., Nagula, K.N., Patwardhan, A.V. and Pandit, A.B., 2020. Alternative and remunerative solid culture media for pigment-producing *Serratiamarcescens* NCIM 5246. *J Text Assoc*, 81(2), pp.99-103.
- [30] Amit Mangal, 2022. "Envisioning the Future of Professional Services: ERP, AI, and Project Management in the Age of Digital Disruption" *ESP Journal of Engineering & Technology Advancements* 2(4): 71-79. [Link]
- [31] Chanthati, Sasibhushan Rao. (2021). How the Power of Machine - Machine Learning, Data Science and NLP Can Be Used to Prevent Spoofing and Reduce Financial Risks. 10.13140/RG.2.2.18761.76640.
- [32] Chanthati, SasibhushanRao. (2021). Second Version on A Centralized Approach to Reducing Burnouts in the IT industry Using Work Pattern Monitoring Using Artificial Intelligence using MongoDB Atlas and Python. 10.13140/RG.2.2.12232.74249.
- [33] Next-Generation Decision Support: Harnessing AI and ML within BRMS Frameworks (N. R. Palakurti , Trans.). (2023). *International Journal of Creative Research in Computer Technology and Design*, 5(5), 1-10. <https://jrctd.in/index.php/IJRCTD/article/view/42>
- [34] Pratiksha Agarwal, Arun Gupta, "Harnessing the Power of Enterprise Resource Planning (ERP) and Customer Relationship Management (CRM) Systems for Sustainable Business Practices," *International Journal of Computer Trends and Technology*, vol. 72, no. 4, pp. 102-110, 2024. Crossref, <https://doi.org/10.14445/22312803/IJCTT-V72I4P113>
- [35] "Optimizing Wiring Harness Minimization through Integration of Internet of Vehicles (IOV) and Internet of Things (IoT) with ESP-32 Module: A Schematic Circuit Approach", *International Journal of Science & Engineering Development Research* ([www.ijrti.org](http://www.ijrti.org)), ISSN:2455-2631, Vol.8, Issue 9, page no.95 - 103, September-2023, Available : <http://www.ijrti.org/papers/IJRTI2309015.pdf>
- [36] Borra, Praveen; Comprehensive Survey of Amazon Web Services (AWS): Techniques, Tools, and Best Practices for Cloud Solutions *INTERNATIONAL RESEARCH JOURNAL OF ADVANCED ENGINEERING AND SCIENCE* 9 3, 24-29, 2024 IRJAES.
- [37] Kalla, Dinesh and Smith, Nathan and Samaah, Fnu and Polimetla, Kiran, Hybrid Scalable Researcher Recommendation System Using Azure Data Lake Analytics (February 2024). *Journal of Data Analysis and Information Processing*, 2024, 12, 76-88 , Available at SSRN: <https://ssrn.com/abstract=4722802>
- [38] Palakurti, N. R. (2023). Governance Strategies for Ensuring Consistency and Compliance in Business Rules Management. *Transactions on Latest Trends in Artificial Intelligence*, 4(4).
- [39] S. Masarath, V. N. Waghmare, S. Kumar, R. S. M. Joshitta, D. D. Rao and Harinakshi, "Storage Matched Systems for Single-click Photo Recognitions using CNN", 2023 International Conference on Communication Security and Artificial Intelligence (ICCSAI), pp. 1-7.
- [40] S. E. Vadakkethil Somanathan Pillai and K. Polimetla, "Integrating Network Security into Software Defined Networking (SDN) Architectures," 2024 International Conference on Integrated Circuits and Communication Systems (ICICACS), Raichur, India, 2024, pp. 1-6, doi: 10.1109/ICICACS60521.2024.10498703.
- [41] Dileep Kumar Pandiya, Nilesh Charankar, 2024, Optimizing Performance and Scalability in Micro Services with CQRS Design, *INTERNATIONAL JOURNAL OF ENGINEERING RESEARCH & TECHNOLOGY (IJERT)* Volume 13, Issue 04 (April 2024).
- [42] Venkata Sathya Kumar Koppiseti, 2024. "Deep Learning: Advancements and Applications in Artificial Intelligence" *ESP International Journal of Advancements in Computational Technology (ESP-IJACT)* Volume 2, Issue 2: 106-113. [Link]
- [43] V. Kumar Nomula, "A Novel Approach to Analyzing Medical Sensor Data Using Physiological Models," *FMDDBTransactions on Sustainable Health Science Letters*, vol. 1, no. 4, pp. 186 -197, 2023.

- [44] S. E. Vadakkethil Somanathan Pillai and K. Polimetla, "Mitigating DDoS Attacks using SDN-based Network Security Measures," 2024 International Conference on Integrated Circuits and Communication Systems (ICICACS), Raichur, India, 2024, pp. 1-7, doi: 10.1109/ICICACS60521.2024.10498932.
- [45] Sachan, V., Malik, S., Gautam, R., & Kumar, P. (Eds.). (2024). *Advances in AI for Biomedical Instrumentation, Electronics and Computing: Proceedings of the 5th International Conference on Advances in AI for Biomedical Instrumentation, Electronics and Computing (ICABEC - 2023)*, 22-23 December 2023, India (1st ed.). CRC Press. <https://doi.org/10.1201/9781032644752>
- [46] S. E. V. S. Pillai and K. Polimetla, "Enhancing Network Privacy through Secure Multi-Party Computation in Cloud Environments," 2024 International Conference on Integrated Circuits and Communication Systems (ICICACS), Raichur, India, 2024, pp. 1-6, doi: 10.1109/ICICACS60521.2024.10498662.
- [47] Praveen Borra "A Survey of Google Cloud Platform (GCP): Features, Services, and Applications" ,International Journal of Advanced Research in Science, Communication and Technology (IJARSCT) ,vol. 4, no. 3, pp. 191 - 199, 2024.
- [48] Naga Ramesh Palakurti, 2023. "Evolving Drug Discovery: Artificial Intelligence and Machine Learning's Impact in Pharmaceutical Research" *ESP Journal of Engineering & Technology Advancements* 3(3): 136-147. [Link]
- [49] Chanthati, S. R. (2024). Website Visitor Analysis & Branding Quality Measurement Using Artificial Intelligence. Sasibhushan Rao Chanthati. <https://journals.e-palli.com/home/index.php/ajet>. <https://doi.org/10.54536/ajet.v3i3.3212>
- [50] Naga Ramesh Palakurti, 2022. "AI Applications in Food Safety and Quality Control" *ESP Journal of Engineering & Technology Advancements* 2(3): 48-61. [Link]
- [51] Chanthati, S. R. (2024). An automated process in building organic branding opportunity, budget Intensity, recommendation in seasons with Google trends data. Sasibhushan Rao Chanthati. <https://doi.org/10.30574/wjaets.2024.12.2.0326>
- [52] Kumar Shukla, Shashikant Tank, 2024. "CYBERSECURITY MEASURES FOR SAFEGUARDING INFRASTRUCTURE FROM RANSOMWARE AND EMERGING THREATS", *International Journal of Emerging Technologies and Innovative Research* (www.jetir.org), ISSN: 2349-5162, Vol.11, Issue 5, page no.i229-i235, May-2024, Available: <http://www.jetir.org/papers/JETIR2405830.pdf>
- [53] Jacopo Pianigiani, Manish Krishnan, Anantharamu Suryanarayana, Vivekananda Shenoy, 2020. *Cloud Network Having Multiple Protocols Using Virtualization Overlays across Physical and Virtualized Workloads*, US10880210B2. [Link]
- [54] Shashikant Tank, Kumar Shukla, 2024."A COMPARATIVE ANALYSIS OF NVMe SSD CLASSIFICATION TECHNIQUES", *International Journal of Emerging Technologies and Innovative Research* (www.jetir.org), ISSN: 2349-5162, Vol.11, Issue 5, page no.c261-c266, May-2024, Available : <http://www.jetir.org/papers/JETIR2405231.pdf>
- [55] Chandrakanth Lekkala (2023) Deploying and Managing Containerized Data Workloads on Amazon EKS. *Journal of Artificial Intelligence & Cloud Computing*. SRC/JAICC-342. DOI: doi.org/10.47363/JAICC/2023 (2)324.
- [56] Patel, N. (2024, March). SECURE ACCESS SERVICE EDGE(SASE): "EVALUATING THE IMPACT OF CONVERGED NETWORK SECURITY ARCHITECTURES IN CLOUD COMPUTING." *Journal of Emerging Technologies and Innovative Research*. <https://www.jetir.org/papers/JETIR2403481.pdf>
- [57] Ayyalasoamayajula, Madan Mohan Tito, Sathishkumar Chintala, and Sandeep Reddy Narani. "Optimizing Textile Manufacturing With Neural Network Decision Support: An Ornstein-Uhlenbeck Reinforcement Learning Approach." *Journal of Namibian Studies: History Politics Culture* 35 (2023): 335-358.
- [58] Vishwanath Gojanur , Aparna Bhat, "Wireless Personal Health Monitoring System", *IJETCAS:International Journal of Emerging Technologies in Computational and Applied Sciences*,eISSN: 2279-0055,pISSN: 2279-0047, 2014. [Link]
- [59] Ayyalasoamayajula, Madan Mohan Tito, et al. "Proactive Scaling Strategies for Cost-Efficient Hyperparameter Optimization in Cloud-Based Machine Learning Models: A Comprehensive Review." *ESP Journal of Engineering & Technology Advancements (ESP JETA)* 1.2 (2021): 42-56.
- [60] Mistry, H., Shukla, K., & Patel, N. (2024). Transforming Incident Responses, Automating Security Measures, and Revolutionizing Defence Strategies through AI-Powered Cybersecurity. *Journal of Emerging Technologies and Innovative Research*, 11(3), 25. <https://www.jetir.org/>
- [61] Ayyalasoamayajula, M., & Chintala, S. (2020). Fast Parallelizable Cassava Plant Disease Detection using Ensemble Learning with Fine Tuned AmoebaNet and ResNeXt-101. *Turkish Journal of Computer and Mathematics Education (TURCOMAT)*, 11(3), 3013-3023.
- [62] Aparna Bhat, "Comparison of Clustering Algorithms and Clustering Protocols in Heterogeneous Wireless Sensor Networks: A Survey," 2014 INTERNATIONAL JOURNAL OF SCIENTIFIC PROGRESS AND RESEARCH (IJSPPR)-ISSN : 2349-4689 Volume 04- NO.1, 2014. [Link]
- [63] Ayyalasoamayajula, Madan Mohan Tito, et al. "Implementing Convolutional Neural Networks for Automated Disease Diagnosis in Telemedicine." 2024 Third International Conference on Distributed Computing and Electrical Circuits and Electronics (ICDCECE). IEEE, 2024.
- [64] Shashikant Tank Kumar Mahendrabhai Shukla, Nimeshkumar Patel, Veeral Patel, 2024." AI BASED CYBER SECURITY DATA ANALYTIC DEVICE", 414425-001, [Link]

- [65] Ayyalasomayajula, Madan Mohan Tito, Akshay Agarwal, and Shah Nawaz Khan. "Reddit social media text analysis for depression prediction: using logistic regression with enhanced term frequency-inverse document frequency features." *International Journal of Electrical and Computer Engineering (IJECE)* 14.5 (2024): 5998-6005.
- [66] Aparna Bhat, Rajeshwari Hegde, "Comprehensive Study of Renewable Energy Resources and Present Scenario in India," 2015 IEEE International Conference on Engineering and Technology (ICETECH), Coimbatore, TN, India, 2015. [Link]
- [67] Ayyalasomayajula, Madan Mohan Tito. "Innovative Water Quality Prediction For Efficient Management Using Ensemble Learning." *Educational Administration: Theory and Practice* 29.4 (2023): 2374-2381.
- [68] Sarangkumar Radadia Kumar Mahendrabhai Shukla ,Nimeshkumar Patel ,Hirenkumar Mistry,Keyur Dodiya 2024." CYBER SECURITY DETECTING AND ALERTING DEVICE", 412409-001, [Link]
- [69] Ayyalasomayajula, Madan Mohan Tito, Srikrishna Ayyalasomayajula, and Sailaja Ayyalasomayajula. "Efficient Dental X-Ray Bone Loss Classification: Ensemble Learning With Fine-Tuned VIT-G/14 And Coatnet-7 For Detecting Localized Vs. Generalized Depleted Alveolar Bone." *Educational Administration: Theory and Practice* 28.02 (2022).
- [70] Aparna K Bhat, Rajeshwari Hegde, 2014. "Comprehensive Analysis Of Acoustic Echo Cancellation Algorithms On DSP Processor", *International Journal of Advance Computational Engineering and Networking (IJACEN)*, volume 2, Issue 9, pp.6-11. [Link]
- [71] Ayyalasomayajula, M. M. T., Chintala, S., & Sailaja, A. (2019). A Cost-Effective Analysis of Machine Learning Workloads in Public Clouds: Is AutoML Always Worth Using? *International Journal of Computer Science Trends and Technology (IJCST)*, 7(5), 107-115.
- [72] Nimeshkumar Patel, 2022." QUANTUM CRYPTOGRAPHY IN HEALTHCARE INFORMATION SYSTEMS: ENHANCING SECURITY IN MEDICAL DATA STORAGE AND COMMUNICATION", *Journal of Emerging Technologies and Innovative Research*, volume 9, issue 8, pp.g193-g202. [Link]
- [73] Bhat, A., & Gojanur, V. (2015). Evolution Of 4g: A Study. *International Journal of Innovative Research in Computer Science & Engineering (IJIRCSE)*. Booth, K. (2020, December 4). How 5G is breaking new ground in the construction industry. *BDC Magazine*.<https://bdcmagazine.com/2020/12/how-5g-is-breaking-new-ground-in-the-constructionindustry/>. [Link]
- [74] Nimeshkumar Patel, 2021." SUSTAINABLE SMART CITIES: LEVERAGING IOT AND DATA ANALYTICS FOR ENERGY EFFICIENCY AND URBAN DEVELOPMENT", *Journal of Emerging Technologies and Innovative Research*, volume 8, Issue 3, pp.313-319. [Link]
- [75] Bhat, A., Gojanur, V., & Hegde, R. (2014). 5G evolution and need: A study. In *International conference on electrical, electronics, signals, communication and optimization (EESCO) – 2015*. [Link]
- [76] Chintala, S. ., & Ayyalasomayajula, M. M. T. . (2019). OPTIMIZING PREDICTIVE ACCURACY WITH GRADIENT BOOSTED TREES IN FINANCIAL FORECASTING. *Turkish Journal of Computer and Mathematics Education (TURCOMAT)*, 10(3), 1710-1721. <https://doi.org/10.61841/turcomat.v10i3.14707>
- [77] A. Bhat, V. Gojanur, and R. Hegde. 2015. 4G protocol and architecture for BYOD over Cloud Computing. In *Communications and Signal Processing (ICCSPP)*, 2015 International Conference on. 0308-0313. Google Scholar. [Link]
- [78] Ankitkumar Tejani, Harsh Gajjar, Vinay Toshniwal, Rashi Kandelwal, 2022. "The Impact of Low-GWP Refrigerants on Environmental Sustainability: An Examination of Recent Advances in Refrigeration Systems" *ESP Journal of Engineering & Technology Advancements* 2(2): 62-77. [Link]
- [79] Ankitkumar Tejani, Jyoti Yadav, Vinay Toshniwal, Harsha Gajjar, 2022. "Natural Refrigerants in the Future of Refrigeration: Strategies for Eco-Friendly Cooling Transitions", *ESP Journal of Engineering & Technology Advancements*, 2(1): 80-91. [Link]
- [80] Vikramraj Kumar Thiyagarajan, 2024. "Financial Transformation: Redefining Consolidation Processes with Oracle FCCS", *International Journal of Innovative Research of science, Engineering and technology (IJIRSET)*, Volume 13, Issue 9, [Link]
- [81] Gokul Ramadoss , 2022." Care and Disease Management: Why Managed Care Organizations (MCOs) Need to have an Inclusive Approach to Patient Care", *Progress in Medical Science*, VOL 6, NO. 3, PAGE 1 - 5, [Link]
- [82] Gokul Ramadoss , 2022." EHR & EMR - A Wholesome View on its Impact in EDI Transaction", *Progress in Medical Science*, VOL 6, NO. 5, PAGE 1 - 4, [Link]
- [83] Radhika Kanubaddhi, "Real-Time Recommendation Engine: A Hybrid Approach Using Oracle RTD, Polynomial Regression, and Naive Bayes," *SSRG International Journal of Computer Science and Engineering* , vol. 8, no. 3, pp. 11-16, 2021. Crossref, <https://doi.org/10.14445/23488387/IJCSE-V8I3P103>
- [84] Radhika Kanubaddhi, 2022. "Designing an Enterprise-Grade, Cloud-Native Chatbot Solution for the Hospitality Industry Using Azure QnA Maker and Azure LUIS", *ESP Journal of Engineering & Technology Advancements*, 2(1): 56-62. <https://espieta.org/jeta-v2i1p108>
- [85] Sunil Kumar Suvvari (2022). Managing Project Scope Creep: Strategies for Containing Changes. *Innovative Research Thoughts*, 8(4), 360-371. <https://doi.org/10.36676/irt.v8.i4.1475>
- [86] Sunil Kumar Suvvari (2022). Project Portfolio Management: Best Practices for Strategic Alignment. *Innovative Research Thoughts*, 8(4), 372-385. <https://doi.org/10.36676/irt.v8.i4.1476>

- [87] Sunil Kumar Suvvari (n.d.). *Project manager, University of Central Missouri, 116 W South St, Warrensburg, Missouri, USA, 64093.* <https://doi.org/10.56726/IRJMETS18095>