

Original Article

Cost-Effective 3D Printed Myoelectric Prosthetic Arm Using Arduino

M.Chandrasekar¹, S.Veerapandian², M.Vasantha Prasanna³, J.Muthirulu⁴, A.Patchamuthu⁵

^{1,2,3}Dept. of Electronics and Communication Engineering, M.A.M School of Engineering, Tamilnadu, India.

^{4,5}Dept. of Computer Science Engineering, M.A.M School of Engineering, Tamilnadu, India.

Abstract: The number of people with impairments has been alarmingly increasing over the previous ten years due to a number of variables, including long-term diseases, aging populations, and increased population growth. Particularly, limb amputation poses complex issues because it impacts one's work, self-perception, family dynamics, and bodily feeling and function. It is suggested to use bionic arms to remedy this problem. Signals from an amputee muscle are gathered by bionic arms to function. Electrodes for an EMG sensor are used to pick up signals from the muscle fibers and produce the necessary output. The two main processes involved in processing EMG signals are signal amplification and filtering. This inexpensive bionic arm was created by 3D printing, which has benefits of its own. To reduce noise and amplify the signal, it is routed through a series of filters and amplifiers. Digital signals are created from the analog signal. Using a microprocessor, these digital signals are utilized to operate the servo motors. The acquired EMG signals are processed to extract particular features. The servo motors installed within the 3D-designed arm are linked to the EMG electrodes. Most 3D printed filament is made of PLA plastic.

Keywords: Limb Amputation, Bionics Arm, EMG Sensors, Noise, 3D Printed Technology, DIY Muscle Sensor, Bioelectric Signals, EMG Signal Measurement.

INTRODUCTION

Objectives:

The primary objective is to restore the function of a lost limb. The primary goal is to create a hand by designing an affordable EMG control platform and a mechanical hand that can be made cheaply on a 3D printer. To attain a high degree of hand functionality, we implemented a user interface that allows the user to call many more hand functions.

Overview:

One of the most often used management interfaces in modern progressive upper limb medicine is electromyography (EMG). Prosthetic arms that use an electromyographic interface are called myoelectric arms. Myoelectric hands are the hands that are used in these types of situations. After that, the expense of these technical applications on an advertisement-sized screen is high—myoelectric hands can cost anywhere from \$15,000 to \$50,000.

The maintenance procedures that these hands typically need involve the use of expensive proprietary parts and the presence of a highly qualified and experienced specialist throughout the repair process. A myoelectric prosthesis can be very expensive, which prevents many amputees worldwide from being able to enjoy using one. It is well recognized that the most affordable and often used myoelectric hands (which cost roughly \$15,000) are not as useful as a typical human hand. The pinch grip is the only grip that these hands can offer their users.

The EMG system allows the user to control and adjust the speed of these hands. However, because the hand's velocity will shatter objects, users should use caution when producing a shot to grasp anything. Around the world, there are a number of advanced hands that are significantly more useful than the most affordable ones. For instance, because the Be branch of knowledge and I-Limb can transition between different grips and finger movements, they have these options. Sadly, while the World Health Organization might be able to pay for it for a tiny portion of amputees, these hands are quite costly for the majority of them.



We've made the decision to create the ultimate hand with the same options and functionalities as the most delicate current myoelectric hands in an attempt to make this vital technology accessible to the average unfortunate user, given the stark disparity between cost and usefulness. Our goal of creating a high-tech hand will be accomplished by creating an interface that lets the user operate many hand functions. Multiple impulse user interfaces have reduced the chance of a stray muscle impulse, which has reduced unintended motions and unintentional hand propulsion. This lessens the strain of the user's mental task.

The user's myogram signals are mechanically recorded when their residual limb is activated. With the aid of an analog-to-digital converter, this signal is enhanced and transformed. A serial peripheral link is then used to transmit the digitalized signal to the microcontroller. The microprocessor detects the muscle signals, causing the hand's motors to become active. The way the user creates a series of successive impulses controls how the mechanical hand operates. The user can be informed about the status of the gadget by exteroception feedback if the hand's management logic identifies a perform choice.

EXISTING SYSTEM

There are three types in the existing system, named as

- Cosmetic Hand
- Threaded Arm
- Electric Arm
- Mechanical Arm

Cosmetic Arm:

These hands are constructed from flexible, lightweight foam wrapped around a metal skeleton fixed on a plastic base. The skeleton allows you to place individual digits. On most sizes, the base may be attached to round or oval hand plates, as well as M12 threaded stems. A broader selection of cosmetic hands is also available, with longer wires and no internal base. These are used to make cosmetic prosthesis for people with incomplete hands.

Threaded Arm:

This method's idea is to tie a knot in a fishing line or thread at the tips of the fingers, then link that same thread to the wrist or another location on the forearm. The fingers then fold as the wrist rotates, pushing the threads back. In order to draw the strings using this method, you must move your wrist. Nevertheless, it's a great solution because it can be made for a very low cost using the latest 3D printers, and the parts are easy to design and even available for free online.



Figure 1: Threaded Arm

Electric Arm:

These prostheses use wrist, elbow, or terminal device electronic motors that run on a rechargeable battery. There are other ways to operate these prostheses, such as using servo control through a button switch harness or push button. In addition to obvious disadvantages like weight and moisture exposure, it is more costly to purchase and maintain.



Figure 2: Electric Arm

Mechanical Arm:

The mechanical hands are devices that are used with the function of opening or voluntary closure by means of a harness which is fastened around the shoulders, chest and part of user controlled arm. Its operation is based on the extension of a league through the harness for open or close, and closing or opening is made only with muscle relaxation respectively by a spring to perform a pressure force or pinch. Due to these prostheses are driven by the body, it is necessary that you have at least a general movement: chest expansion, depression and shoulder elevation.

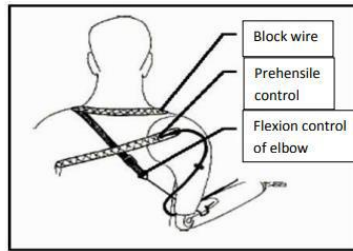

Figure 3: Mechanical Arm

Problem Statement:

There are certain challenges and discomforts associated with utilizing existing types of arms since the arm is heavy, the metal arm causes a wound in the missing limb during use, and the electromechanical arm is quite costly. So, we need a way to minimize exorbitant costs, wounds, and weightlessness, as well as making the arm adaptable.

- Symptoms may include intact limb pain, back pain, inadequate prosthetics, poor balance, instability, fear of falling, fatigue, reduced mobility, irritation, and skin issues.
- Bionic limbs may induce implant stability difficulties, bone fractures, implant breakage, and infections. All of these bad situations share various harmful consequences. They create agony. High-tech bespoke prostheses, such as the Electric Arm for amputees, are now accessible in India for half the price of imported ones, which may cost upwards of Rs 1.5 lakh.
- Folding mechanical fingers in prosthetic hands can be tricky and uncomfortable. Prosthetic arms are pricey because they require high-cost materials such as carbon. The mechanical and electromechanical prosthetic hands are not customizable.

PROPOSED SYSTEM

3d Printing Technologies:

A wide range of printing ingredients, such as thermoplastic polymers, photosensitive polymers, molding sands for casting, square measure metal powders, and others, are handled differently when using 3D printing techniques. Compared to conventional production methods, 3D writing is different. Conventional machining involves removing the cloth. The contrary is true according to the principle of 3D printing: fabric is added. The ultimate three-dimensional form "grows" in layers. This explains why additive manufacturing (AM) refers to a broad spectrum of outputs. When compared to the industry norm, those technologies' drawbacks include worse

mechanical quality, higher business machinery values, and higher input material costs. Fortunately, there is a wide range of open technology available these days.

FFF (Fused Filament Fabrication) technology is one of the most well-known nonproprietary processes. It is the same technique as Fused Deposition Modelling (FDM), a registered trademark of the Stratasys company but already non-proprietary. Filaments made of thermoplastic polymers are used in all of the methods. Liquid material is ejected onto an electrically controlled moving table by a thermally controlled nozzle. A single layer deposition table is positioned at a comparable distance due to the layer's thickness.

Until the half is not designed, the 3D method is applied again. A lot of novel applications for 3D printing have been made possible by patent protection in the field. Reducing manufacturing costs financially, using open materials to lessen unpredictability, and speeding up production are the main tenets (ideas, goals). Open supply can manage most 3D printing parameters (temperature, movement speed, hatching, etc.) because it has no such limitations. Construction tables made with composite material experience less internal material stress as a result of temperature variations when temperature is tightly controlled. Open supply warms building tables, reducing this effect. Sadly, huge 3D models with internal tension are not well suited for this resolution, which could damage the written model. There are a few considerations to make when creating 3D models for 3D printing. The following text presents the key ideas and firsthand accounts from several groups of 3D printer users.

Take care when printing walls that are either too high or too narrow. If you write thin walls without a framework, the weight of the wall will cause the wall to bend. It is advised to take the 3D written contour's thickness and height into account. Four layers is the recommended wall thickness for FFF or FDM technologies. Usually, there is no wall thickness.25 mm. This criterion is dependent on the method and material employed, hence it is not applicable to all 3D technologies.

Upper Limb Prosthesis:

Prosthetics employ artificial devices to replace lost bodily parts. This text covers only a small portion of this sophisticated domain. It primarily addresses higher limb restorative (ULP) and below-elbow restorative issues. For better comprehension, it is necessary to begin this section with a quick taxonomy of prostheses, as well as fundamental hand grips and motions.

Classification of ULPS can be done as follows:

Passive

- Cosmetic Prosthesis (Cosmesis)

Active

- Conventional (Body-Powered) Prostheses
- Electrically Powered Prostheses
- Myoelectric Control
- Servo Control
- Push Button Control
- Harness Switch Control

There are more hybrid types of prosthesis that are outdated or insignificant, but they were not included in the list. Human grip taxonomies, as examined and contrasted, play an important role in establishing a common language in domains such as human-computer interaction. The authors outline seventeen general grips from thirty-three types. We like to employ for our functions a list of grips and gestures described on open technology project websites (similar to the hackberry project):

- Grips
- Pinch grip
- Hook
- Tripod grip
- Gestures

- Full open / close
- Thumbs up / down
- Index finger point

ULP covers a wide range of economic topics and offers a variety of hands-on opportunities. High-tech versions of myoelectric prosthesis are described, including the bionic stepper, Michelangelo of Otto lager beer, and the I-limb of Bit technology. There are further research institutions and companies that focus on knowledge domain activities such as robotic hands, sophisticated upper-extremity prosthetic devices, etc.

The following open supply initiatives inspired us the most: alter, Limb it Less, Not Possible, Open Technology, ROMP, You Bionic, and MHK Community. Volunteers in these programs employ more accessible 3D technology for prosthesis fabrication and share their skills with people of their communities. The primary goal of these operations is to bring new technology and their products, prostheses, as close as possible to the people who have them.

PROPOSING METHOD

The proposed system creates prosthetic arms using 3D printing, which is inexpensive. By configuring the EMG muscle sensor using ARDUINO NANO, we can more easily control the arm. It will be considerably more user-friendly, which means they will be easier to adjust to meet the needs of the user. 3D printed prostheses weigh less than other prosthetics.

Block Diagram of Proposed System

Block diagrams help you understand and construct whole circuits by breaking them down into smaller portions or blocks. Each of the blocks in the design performs a certain job, and the block diagram demonstrates how they are joined together. Figure 3.1 shows the overall block diagram of the circuit. As indicated by the picture, the design is separated into three major components: the electronics circuit on the PCB, the hand, and the external devices/power input.

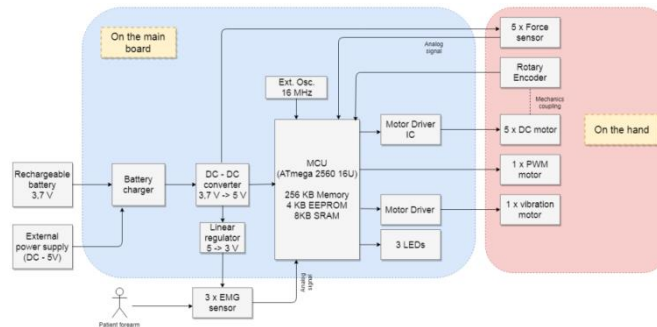

Figure 4: Block Diagram of the Proposed System

Figure 3.1 shows the part in blue square is on the PCB circuit. These elements are electrical components without mechanical capability. The pink-colored square represents mechanical components connected directly to the 3D printed hand. The EMG sensors are connected to the user's forearm and are not part of the main PCB, as seen in the diagram. These sensors transmit analog signals to the microcontroller and are connected to the main board by wires. The prosthetic hand needs EMG sensors because they must be mounted to the forearm and placed in the correct muscle position to gather signals.

EMG Sensor:

Out of the many various EMG sensors on the market, the MyoWare Muscle Sensor (AT-04-001), made by Advancer Technologies, was chosen for this specific project. MyoWare sensor is a module-based circuit. This sensor consists of biomedical sensor pads, an integrated circuit, and a PCB board. It has been built as a wearable device, which means it may be placed directly on the body since biomedical sensor pads are linked directly to the PCB

board rather than utilizing biomedical pads separately and connecting them with wires. Figure 3.1 depicts Myoware Muscle Sensors, and table 3.1 provides electrical specifications for the sensor.



Figure 5: EMG Sensor (AT-04-001)

Table 1: Electrical Specification of EMG Sensor (AT-04-001)

Parameter	Min	TYP	Max
Supply Voltage	+2.9V	+3.3V or +5V	+5.7V
Adjustable Gain Potentiometer	0.01 Ohm	50 k Ω	100 k Ω
Output Signal Voltage			
EMG Envelop	0V	--	+Vs
Raw EMG (Centered about +Vs/2)	0V	--	+Vs
Input Impedance	--	110 G Ω	--
Supply Current	--	9 mA	14 mA
Common Mode Rejection Ratio	--	110	--
Input Bias	--	1 PA	--

Advantages:

- Reducing Weight.
- Avoid from getting wound.
- Avoid from hand pain.
- The 3D printing filaments are Eco-Friendly.

CONCLUSION AND FUTURE SCOPE

The EMG technique can be helpful in symptomatic innovation whenever there is concern for mononeuropathy (Carpal Burrow Disorder, Wrist Drop, Foot Drop), polyneuropathies, or radiculopathies (when MRI does not detect nerve root compression). Using EMG technology, the clutters of the Neuro-Muscular junction (Myasthenia Gravis) can also be recognized. To diagnose various diseases and disorders of the muscles, special needle electrodes are used. In the market for prototypes, 3D printing has an advantage and always will. Any product's customisation, rapid prototyping, and research depend heavily on this technology. In the near future, this industry might offer a variety of work opportunities.

REFERENCES

[1] Ryait, H.S., Arora, A.S. & Agarwal, R. Study of issues in the development of surface EMG controlled human hand. J Mater Sci: Mater Med 20, 107 (2009).

[2] C. Cipriani, F. Zaccone, S. Micera and M. C. Carrozza, "On the Shared Control of an EMG-Controlled Prosthetic Hand: Analysis of User- Prosthesis Interaction," in IEEE Transactions on Robotics, vol. 24, no. 1, pp. 170-184, Feb. 2008.

[3] Y. Su, M. H. Fisher, A. Wolczowski, G. D. Bell, D. J. Burn and R. X. Gao, "Towards an EMG-Controlled Prosthetic Hand Using a 3-D Electromagnetic Positioning System," in IEEE Transactions on Instrumentation and Measurement, vol. 56, no. 1, pp. 178-186, Feb. 2007.

- [4] M. Gauthaam and S. Sathish Kumar, "EMG controlled bionic arm," 2011 National Conference on Innovations in Emerging Technology, Erode, Tamilnadu, 2011, pp. 111-114.
- [5] K. Ito et al., "Compliance control of an EMG-controlled prosthetic forearm using ultrasonic motors," Proceedings of IEEE/RSJ International Conference on Intelligent Robots and Systems (IROS'94), Munich, Germany, 1994, pp. 1816-1823 vol.3.
- [6] G. N. Saridis and H. E. Stephanou, "Hierarchically intelligent control of a bionic arm," 1975 IEEE Conference on Decision and Control including the 14th Symposium on Adaptive Processes, Houston, TX, USA, 1975, pp. 99-104.
- [7] K. Sharmila, T. V. Sarath and K. I. Ramachandran, "EMG controlled low cost prosthetic arm," 2016 IEEE Distributed Computing, VLSI, Electrical Circuits and Robotics (DISCOVER), Mangalore, 2016, pp. 169-172.
- [8] T. Tsuj, O. Fukuda, H. Shigeyoshi and M. Kaneko, "Bio-mimetic impedance control of an EMG-controlled prosthetic hand," Proceedings 2000 IEEE/RSJ International Conference on Intelligent Robots and Systems (IROS 2000) (Cat. No.00CH37113), Takamatsu, Japan, 2000, pp. 377-382 vol.1.
- [9] Naresh Kumar Miryala, Divit Gupta, "Data Security Challenges and Industry Trends" IJARCCCE International Journal of Advanced Research in Computer and Communication Engineering, vol. 11, no.11, pp. 300-309, 2022, Crossref<https://doi.org/10.17148/IJARCCCE.2022.111160>
- [10] Akhilandeswari, P., George, J.G. (2014). Secure Text Steganography. In: Sathiakumar, S., Awasthi, L., Masillamani, M., Sridhar, S. (eds) Proceedings of International Conference on Internet Computing and Information Communications. Advances in Intelligent Systems and Computing, vol 216. Springer, New Delhi. https://doi.org/10.1007/978-81-322-1299-7_1
- [11] Ashween. Ganesh, *Critical Evaluation of Low Ergonomics Risk Awareness among Early Product Development Stage of the Medical Device Industry*, pp. 15, 2022. | Google Scholar
- [12] KushalWalia, 2024. "Accelerating AI and Machine Learning in the Cloud: The Role of Semiconductor Technologies" *ESP International Journal of Advancements in Computational Technology (ESP-IJACT)* Volume 2, Issue 2: 34-41. | Google Scholar
- [13] Julian, Anitha , Mary, Gerardine Immaculate , Selvi, S. , Rele, Mayur& Vaithianathan, Muthukumaran (2024) Blockchain based solutions for privacy-preserving authentication and authorization in networks, *Journal of Discrete Mathematical Sciences and Cryptography*, 27:2-B, 797-808, DOI: 10.47974/JDMSC-1956
- [14] Sridhar Selvaraj, 2024. "Futuristic SAP Fiori Dominance" *ESP International Journal of Advancements in Computational Technology (ESP-IJACT)* Volume 2, Issue 1: 32-37. | Google Scholar
- [15] Bhattacharya, S. (2024). Securing the Gatekeeper: Addressing Vulnerabilities in OAuth Implementations for Enhanced Web Security. *International Journal of Global Innovations and Solutions (IJGIS)*. <https://doi.org/10.21428/e90189c8.af381673>
- [16] VenkataSathya Kumar Koppiseti, "Automation of Vendor Invoice Process with OpenText Vendor Invoice Management," *International Journal of Computer Trends and Technology*, vol. 71, no. 8, pp. 71-75, 2023. Crossref, <https://doi.org/10.14445/22312803/IJCTT-V71I8P111>
- [17] SumanthTatineni, AnirudhMustyala, 2024. "Enhancing Financial Security: Data Science's Role in Risk Management and Fraud Detection" *ESP International Journal of Advancements in Computational Technology (ESP-IJACT)* Volume 2, Issue 2: 94-105.
- [18] ArnabDey, 2021. "Implementing Latest Technologies from Scratch: A Strategic Approach for Application Longevity" *European Journal of Advances in Engineering and Technology*, 2021, 8 (8): 22-26. | PDF
- [19] DhamotharanSeenivasan, MuthukumaranVaithianathan, 2023. "Real-Time Adaptation: Change Data Capture in Modern Computer Architecture" *ESP International Journal of Advancements in Computational Technology (ESP-IJACT)* Volume 1, Issue 2: 49-61
- [20] "Optimizing Wiring Harness Minimization through Integration of Internet of Vehicles (IOV) and Internet of Things (IoT) with ESP-32 Module: A Schematic Circuit Approach", *International Journal of Science & Engineering Development Research* (www.ijrti.org), ISSN:2455-2631, Vol.8, Issue 9, page no.95 - 103, September-2023, Available : <http://www.ijrti.org/papers/IJRTI2309015.pdf>
- [21] Vijay Panwar, "AI-Powered Data Cleansing: Innovative Approaches for Ensuring Database Integrity and Accuracy," *International Journal of Computer Trends and Technology*, vol. 72, no. 4, pp. 116-122, 2024. Crossref, <https://doi.org/10.14445/22312803/IJCTT-V72I4P115>
- [22] Dixit, A., Sabnis, A. and Shetty, A., 2022. Antimicrobial edible films and coatings based on N, O-carboxymethyl chitosan incorporated with ferula asafoetida (Hing) and adhatodavasica (Adulsa) extract. *Advances in Materials and Processing Technologies*, 8(3), pp.2699-2715.
- [23] AmitMangal, 2024. *Role of Enterprise Resource Planning Software (ERP) In Driving Circular Economy Practices in the United States*, *ESP Journal of Engineering & Technology Advancements* 4(3): 1-8. [Link]
- [24] Chanthathi, SasibhushanRao. (2021). Second Version on A Centralized Approach to Reducing Burnouts in the IT industry Using Work Pattern Monitoring Using Artificial Intelligence using MongoDB Atlas and Python. 10.13140/RG.2.2.12232.74249.

- [25] Pandiya, D. K. (2022). Performance Analysis of Microservices Architecture in Cloud Environments . International Journal on Recent and Innovation Trends in Computing and Communication, 10(12), 264-274. Retrieved from <https://ijritcc.org/index.php/ijritcc/article/view/10745>
- [26] Chanthati, S. R. (2024). Product Colour Variation Management with Artificial Intelligence. Sasibhushan Rao Chanthati. American Journal of Education and Technology, 3(3), 46-52. <https://doi.org/10.54536/ajet.v3i3.3213>
- [27] VenkataSathya Kumar Koppiseti, 2024. "Robotic Process Automation: Streamlining Operations in the Digital Era" *ESP International Journal of Advancements in Computational Technology (ESP-IJACT)* Volume 2, Issue 2: 74-81. [Link]
- [28] Gaayathri, R. S., Rajest, S. S., Nomula, V. K., & Regin, R. (2023). Bud-D: enabling bidirectional communication with ChatGPT by adding listening and speaking capabilities. *FMDB Transactions on Sustainable Computer Letters*, 1(1), 49-63.
- [29] Next-Generation Decision Support: Harnessing AI and ML within BRMS Frameworks (N. R. Palakurti, Trans.). (2023). *International Journal of Creative Research in Computer Technology and Design*, 5(5), 1-10. <https://jrctd.in/index.php/IJRCTD/article/view/42>
- [30] PratikshaAgarwal, Arun Gupta, "Harnessing the Power of Enterprise Resource Planning (ERP) and Customer Relationship Management (CRM) Systems for Sustainable Business Practices," *International Journal of Computer Trends and Technology*, vol. 72, no. 4, pp. 102-110, 2024. Crossref, <https://doi.org/10.14445/22312803/IJCTT-V72I4P113>
- [31] Chanthati, Sasibhushan Rao. (2021). How the Power of Machine - Machine Learning, Data Science and NLP Can Be Used to Prevent Spoofing and Reduce Financial Risks. 10.13140/RG.2.2.18761.76640.
- [32] "Optimizing Wiring Harness Minimization through Integration of Internet of Vehicles (IOV) and Internet of Things (IoT) with ESP-32 Module: A Schematic Circuit Approach", *International Journal of Science & Engineering Development Research* (www.ijrti.org), ISSN:2455-2631, Vol.8, Issue 9, page no.95 - 103, September-2023, Available : <http://www.ijrti.org/papers/IJRTI2309015.pdf>
- [33] Borra, Praveen; Exploring Microsoft Azure's Cloud Computing: A Comprehensive Assessment *International Journal of Advanced Research in Science, Communication and Technology* 2 8, 897-906, 2022 IJAR SCT.
- [34] Kalla, Dinesh and Smith, Nathan and Samaah, Fnu and Polimetla, Kiran, Facial Emotion and Sentiment Detection Using Convolutional Neural Network (January 2021). *Indian Journal of Artificial Intelligence Research (INDJAIR)*, Volume 1, Issue 1, January-December 2021, pp. 1-13, Article ID: INDJAIR_01_01_001, Available at SSRN: <https://ssrn.com/abstract=4690960>
- [35] S. E. VadakkethilSomanathanPillai and K. Polimetla, "Analyzing the Impact of Quantum Cryptography on Network Security," 2024 International Conference on Integrated Circuits and Communication Systems (ICICACS), Raichur, India, 2024, pp. 1-6, doi: 10.1109/ICICACS60521.2024.10498417.
- [36] D. A. Hassan, "Software Security - Threats, Vulnerabilities, and Countermeasures: Investigating common security threats, vulnerabilities, and countermeasures in software systems to enhance security posture", *Australian Journal of Machine Learning Research & Applications*, vol. 4, no. 1, pp. 35-45, May 2024, Accessed: Jul. 18, 2024. [Online]. Available: <https://sydneyacademics.com/index.php/ajmlra/article/view/12>
- [37] Palakurti, N. R. (2023). Governance Strategies for Ensuring Consistency and Compliance in Business Rules Management. *Transactions on Latest Trends in Artificial Intelligence*, 4(4).
- [38] M., Arshey and Daniel, Ravuri and Rao, Deepak Dasaratha and Emerson Raja, Joseph and Rao, D. Chandrasekhar and Deshpande, Aniket (2023) Optimizing Routing in Nature-Inspired Algorithms to Improve Performance of Mobile Ad-Hoc Network. *International Journal of Intelligent Systems and Applications in Engineering*, 11 (8S). pp. 508-516. ISSN 2147-6799
- [39] Yadav, A. B. (2023). GEN AI-DRIVEN ELECTRONICS: INNOVATIONS, CHALLENGES AND FUTURE PROSPECTS. *International Congress on Models and Methods in Modern Investigations*, 113-121. Retrieved from <https://conferenceseries.info/index.php/congress/article/view/1609>
- [40] V. Kakani, B. Kesani, N. Thotakura, J. D. Bodapati and L. K. Yenduri, "Decoding Animal Emotions: Predicting Reactions with Deep Learning for Enhanced Understanding," 2024 IEEE 9th International Conference for Convergence in Technology (I2CT), Pune, India, 2024, pp. 1-6, doi: 10.1109/I2CT61223.2024.10543616.
- [41] A. B. Yadav and P. S. Shukla, "Augmentation to water supply scheme using PLC & SCADA," 2011 Nirma University International Conference on Engineering, Ahmedabad, India, 2011, pp. 1-5, doi: 10.1109/NUiConE.2011.6153314.
- [42] Vamsi Katragadda "Ethical AI in Customer Interactions: Implementing Safeguards and Governance Frameworks" *Iconic Research And Engineering Journals* Volume 7 Issue 12 2024 Page 394-397.
- [43] A. Dave, N. Banerjee, and C. Patel, "CARE: Lightweight attack resilient secure boot architecture with onboard recovery for RISC-V based SOC," in *Proc. 22nd Int. Symp. Quality Electron. Design (ISQED)*, Apr. 2021, pp. 516-521.
- [44] Chanthati, S. R. (2024). Artificial Intelligence-Based Cloud Planning and Migration to Cut the Cost of Cloud Sasibhushan Rao Chanthati. *American Journal of Smart Technology and Solutions*, 3(2), 13-24. <https://doi.org/10.54536/ajsts.v3i2.3210>.

- [45] Artificial Intelligence-Based Cloud Planning and Migration to Cut the Cost of Cloud SR Chanthati - Authorea Preprints, 2024 <http://dx.doi.org/10.22541/au.172115306.64736660/v1> Sasi-Rao: SR Chanthati will pick up the Google scholar and Chanthati, S. R. (2024).
- [46] Sarioguz, O., & Miser, E. (2024). Artificial intelligence and participatory leadership: The role of technological transformation in business management and its impact on employee participation. *International Research Journal of Modernization in Engineering, Technology and Science*, 6(2), Article 1618. <https://www.doi.org/10.56726/IRJMETS49539>.
- [47] Bhattacharya, S., & Kewalramani, C. (2024). Securing Virtual Reality: A Multimodal Biometric Authentication Framework for VRaaS. *International Journal of Global Innovations and Solutions (IJGIS)*. <https://doi.org/10.21428/e90189c8.25802e82>
- [48] Chanthati, S. R. (2024). How the power of machine - machine learning, data science and NLP can be used to prevent spoofing and reduce financial risks. Sasibhushan Rao Chanthati. <https://doi.org/10.30574/gjeta.2024.20.2.0149>
- [49] Kumar Shukla, Shashikant Tank, 2024. "CYBERSECURITY MEASURES FOR SAFEGUARDING INFRASTRUCTURE FROM RANSOMWARE AND EMERGING THREATS", *International Journal of Emerging Technologies and Innovative Research (www.jetir.org)*, ISSN: 2349-5162, Vol.11, Issue 5, page no.i229-i235, May-2024, Available: <http://www.jetir.org/papers/JETIR2405830.pdf>
- [50] Sukhdev S. Kapur, Ashok Ganesan, Jacopo Pianigiani, Michal Styszynski, Atul S Moghe, Joseph Williams, Sahana Sekhar Palagrahara Chandrashekar, Tong Jiang, Rishabh Ramakant Tulsian, Manish Krishnan, Soumil Ramesh Kulkarni, Vinod NairJeba Paulaiyan, 2021. *Automation of Maintenance Mode Operations for Network Devices*, US10938660B1. [Link]
- [51] Shashikant Tank, Kumar Shukla, 2024." A COMPARATIVE ANALYSIS OF NVMe SSD CLASSIFICATION TECHNIQUES", *International Journal of Emerging Technologies and Innovative Research (www.jetir.org)*, ISSN: 2349-5162, Vol.11, Issue 5, page no.c261-c266, May-2024, Available : <http://www.jetir.org/papers/JETIR2405231.pdf>
- [52] Chandrakanth Lekkala 2023. "Implementing Efficient Data Versioning and Lineage Tracking in Data Lakes", *Journal of Scientific and Engineering Research*, Volume 10, Issue 8, pp. 117-123. [Link]
- [53] Patel, N. (2024, March). SECURE ACCESS SERVICE EDGE(SASE): "EVALUATING THE IMPACT OF CONVERGED NETWORK SECURITYARCHITECTURES IN CLOUD COMPUTING." *Journal of Emerging Technologies and Innovative Research*. <https://www.jetir.org/papers/JETIR2403481.pdf>
- [54] Ayyalasoamayajula, Madan Mohan Tito, Sathishkumar Chintala, and Sandeep Reddy Narani. "Optimizing Textile Manufacturing With Neural Network Decision Support: An Ornstein-Uhlenbeck Reinforcement Learning Approach." *Journal of Namibian Studies: History Politics Culture* 35 (2023): 335-358.
- [55] Vishwanath Gojanur , Aparna Bhat, "Wireless Personal Health Monitoring System", *IJETCAS:International Journal of Emerging Technologies in Computational and Applied Sciences*,eISSN: 2279-0055,pISSN: 2279-0047, 2014. [Link]
- [56] Ayyalasoamayajula, Madan Mohan Tito, et al. "Proactive Scaling Strategies for Cost-Efficient Hyperparameter Optimization in Cloud-Based Machine Learning Models: A Comprehensive Review." *ESP Journal of Engineering & Technology Advancements (ESP JETA)* 1.2 (2021): 42-56.
- [57] Mistry, H., Shukla, K., & Patel, N. (2024). Transforming Incident Responses, Automating Security Measures, and Revolutionizing Defence Strategies through AI-Powered Cybersecurity. *Journal of Emerging Technologies and Innovative Research*, 11(3), 25. <https://www.jetir.org/>
- [58] Ayyalasoamayajula, M., & Chintala, S. (2020). Fast Parallelizable Cassava Plant Disease Detection using Ensemble Learning with Fine Tuned AmoebaNet and ResNeXt-101. *Turkish Journal of Computer and Mathematics Education (TURCOMAT)*, 11(3), 3013-3023.
- [59] Aparna Bhat, "Comparison of Clustering Algorithms and Clustering Protocols in Heterogeneous Wireless Sensor Networks: A Survey," 2014 *INTERNATIONAL JOURNAL OF SCIENTIFIC PROGRESS AND RESEARCH (IJSPR)*-ISSN : 2349-4689 Volume 04- NO.1, 2014. [Link]
- [60] Ayyalasoamayajula, Madan Mohan Tito, et al. "Implementing Convolutional Neural Networks for Automated Disease Diagnosis in Telemedicine." 2024 *Third International Conference on Distributed Computing and Electrical Circuits and Electronics (ICDCECE)*. IEEE, 2024.
- [61] Shashikant Tank Kumar Mahendrabhai Shukla, Nimeshkumar Patel, Veeral Patel, 2024." AI BASED CYBER SECURITY DATA ANALYTIC DEVICE", 414425-001, [Link]
- [62] Ayyalasoamayajula, Madan Mohan Tito, Akshay Agarwal, and Shah Nawaz Khan. "Reddit social media text analysis for depression prediction: using logistic regression with enhanced term frequency-inverse document frequency features." *International Journal of Electrical and Computer Engineering (IJECE)* 14.5 (2024): 5998-6005.
- [63] Aparna Bhat, Rajeshwari Hegde, "Comprehensive Study of Renewable Energy Resources and Present Scenario in India," 2015 *IEEE International Conference on Engineering and Technology (ICETECH)*, Coimbatore, TN, India, 2015. [Link]
- [64] Ayyalasoamayajula, Madan Mohan Tito. "Innovative Water Quality Prediction For Efficient Management Using Ensemble Learning." *Educational Administration: Theory and Practice* 29.4 (2023): 2374-2381.

- [65] Sarangkumar Radadia Kumar Mahendrabhai Shukla ,Nimeshkumar Patel ,Hirenkumar Mistry,Keyur Dodiya 2024." CYBER SECURITY DETECTING AND ALERTING DEVICE", 412409-001, [Link]
- [66] Ayyalasomayajula, Madan Mohan Tito, Srikrishna Ayyalasomayajula, and Sailaja Ayyalasomayajula. "Efficient Dental X-Ray Bone Loss Classification: Ensemble Learning With Fine-Tuned VIT-G/14 And Coatnet-7 For Detecting Localized Vs. Generalized Depleted Alveolar Bone." Educational Administration: Theory and Practice 28.02 (2022).
- [67] Aparna K Bhat, Rajeshwari Hegde, 2014. "Comprehensive Analysis Of Acoustic Echo Cancellation Algorithms On DSP Processor", International Journal of Advance Computational Engineering and Networking (IJACEN), volume 2, Issue 9, pp.6-11. [Link]
- [68] Ayyalasomayajula, M. M. T., Chintala, S., & Sailaja, A. (2019). A Cost-Effective Analysis of Machine Learning Workloads in Public Clouds: Is AutoML Always Worth Using? International Journal of Computer Science Trends and Technology (IJCST), 7(5), 107-115.
- [69] Nimeshkumar Patel, 2022." QUANTUM CRYPTOGRAPHY IN HEALTHCARE INFORMATION SYSTEMS: ENHANCING SECURITY IN MEDICAL DATA STORAGE AND COMMUNICATION", Journal of Emerging Technologies and Innovative Research, volume 9, issue 8, pp.g193-g202. [Link]
- [70] Bhat, A., & Gojanur, V. (2015). Evolution Of 4g: A Study. International Journal of Innovative Research in Computer Science & Engineering (IJIRCSE). Booth, K. (2020, December 4). How 5G is breaking new ground in the construction industry. BDC Magazine.<https://bdcmagazine.com/2020/12/how-5g-is-breaking-new-ground-in-the-constructionindustry/>. [Link]
- [71] Nimeshkumar Patel, 2021." SUSTAINABLE SMART CITIES: LEVERAGING IOT AND DATA ANALYTICS FOR ENERGY EFFICIENCY AND URBAN DEVELOPMENT", Journal of Emerging Technologies and Innovative Research, volume 8, Issue 3, pp.313-319. [Link]
- [72] Bhat, A., Gojanur, V., & Hegde, R. (2014). 5G evolution and need: A study. In International conference on electrical, electronics, signals, communication and optimization (EESCO) – 2015.[Link]
- [73] Chintala, S. ., & Ayyalasomayajula, M. M. T. . (2019). OPTIMIZING PREDICTIVE ACCURACY WITH GRADIENT BOOSTED TREES IN FINANCIAL FORECASTING. Turkish Journal of Computer and Mathematics Education (TURCOMAT), 10(3), 1710-1721. <https://doi.org/10.61841/turcomat.v10i3.14707>
- [74] A. Bhat, V. Gojanur, and R. Hegde. 2015. 4G protocol and architecture for BYOD over Cloud Computing. In Communications and Signal Processing (ICCSP), 2015 International Conference on. 0308-0313. Google Scholar. [Link]
- [75] M. Hindka, "Securing the Digital Backbone: An In-depth Insights into API Security Patterns and Practices", Computer Science and Engineering, Vol. 14, No. 2, pp. 35-41, 2024.
- [76] M. Hindka, "Design and Analysis of Cyber Security Capability Maturity Model", International Research Journal of Modernization in Engineering Technology and Science, Vol. 6, No. 3, pp. 1706-1710, 2024.
- [77] Hindka, M. (2024, June). Optimization Accuracy of Secured Cloud Systems Using Deep Learning Model. In 2023 4th International Conference on Intelligent Technologies (CONIT) (pp. 1-5). IEEE.
- [78] M. Siva Kumar et al, "Efficient and low latency turbo encoder design using Verilog-Hdl," Int. J. Eng. Technol., vol. 7, no. 1.5, pp. 37-41, Dec. 2018,[Link]
- [79] Kartheek Pamarthi, 2024." Analysis On Opportunities And Challenges Of Ai In The Banking Industry", International Journal of Artificial Intelligence and Data Science, Volume 1, Issue 2:10-23[Link]
- [80] Ankitkumar Tejani, Jyoti Yadav, Vinay Toshniwal, Rashi Kandelwal, 2021. "Detailed Cost-Benefit Analysis of Geothermal HVAC Systems for Residential Applications: Assessing Economic and Performance Factors", ESP Journal of Engineering & Technology Advancements, 1(2): 101-115. [Link]
- [81] Ankitkumar Tejani, Jyoti Yadav, Vinay Toshniwal, Harsha Gajjar, 2022. "Achieving Net-Zero Energy Buildings: The Strategic Role of HVAC Systems in Design and Implementation", ESP Journal of Engineering & Technology Advancements, 2(1): 39-55. [Link]
- [82] Mihir Mehta, 2024." Evaluating the Trade-offs Between Fully Managed LLM Solutions and Customized LLM Architectures: A Comparative Study of Performance, Flexibility, and Response Quality", International Journal of Management, IT & Engineering, volume 14, Issue 10, [Link]
- [83] DHAMELIYA, N., PATEL, B., MADDULA, S. S., & MULLANGI, K. (2024). EDGE COMPUTING IN NETWORK-BASED SYSTEMS: ENHANCING LATENCY-SENSITIVE APPLICATIONS. Journal of Computing and Digital Technologies, 2(1), 1-21, [Link]
- [84] Vedamurthy Gejjegondanahalli Yogeshappa, 2024. "AI - Driven Innovations in Patient Safety: A Comprehensive Review of Quality Care", International Journal of Science and Research (IJSR), Volume 13 Issue 9, September 2024, pp. 815-826, [Link]

- [85] Vikramraj Kumar Thiyagarajan, 2024. "Predictive Modeling for Revenue Forecasting in Oracle EPBCS: A Machine Learning Perspective", *International Journal of Innovative Research of science, Engineering and technology (IJIRSET)*, Volume 13, Issue 4, [Link]
- [86] T Jashwanth Reddy, Voddi Vijay Kumar Reddy, T Akshay Kumar, 2018. "Population Diagnosis System", *International Journal of Advanced Research in Computer and Communication Engineering*, Volume 7, Issue 2, pp. 207-210. Doi: 10.17148/IJARCEE.2018.7238 [Link]
- [87] Kanubaddhi, R. . (2024). Machine Learning Using Cassandra as a Data Source: The Importance of Cassandra's Frozen Collections in Training and Retraining Models . *Journal of Artificial Intelligence General Science (JAIGS)* ISSN:3006-4023, 1(1), 219-228. <https://doi.org/10.60087/jaigs.v1i1.228>
- [88] Radhika Kanubaddhi, Saidaiah Yechuri, Venkata Ramana Kandula, 2024."Survey on using Natural Language Processing (NLP) on Electronic Health Records",*INTERNATIONAL JOURNAL OF ENGINEERING, SCIENCE and - volume 13,issue 5, May 2024, PP 19-23. [Link]*
- [89] Suman, Chintala (2024) *Evolving BI Architectures: Integrating Big Data for Smarter Decision-Making*. *American Journal of Engineering, Mechanics and Architecture*, 2 (8). pp. 72-79. ISSN 2993-2637
- [90] Chintala, Suman & Thiyagarajan, Vikramraj Kumar. (2023). Harnessing AI for Transformative Business Intelligence Strategies. 1. 81-96. 10.56472/25838628/IJACT-V1I3P109.
- [91] Suman Chintala, "Boost Call Center Operations: Google's Speech-to-Text AI Integration," *International Journal of Computer Trends and Technology*, vol. 72, no. 7, pp.83-86, 2024. Crossref, <https://doi.org/10.14445/22312803/IJCTT-V72I7P110>
- [92] Chintala, Suman. (2024). Smart BI Systems: The Role of AI in Modern Business. *ESP Journal of Engineering & Technology Advancements*. 10.56472/25832646/JETA-V4I3P05. Suvvari, S. K. (2024). Ensuring security and compliance in agile cloud infrastructure projects. *International Journal of Computing and Engineering*, 6(4), 54-73. <https://doi.org/10.47941/ijce.2222>
- [93] Sunil Kumar Suvvari (2024). Building an architectural runway: Emergent practices in agile methodologies. *International Journal of Science and Research (IJSR)*, 13(9), 140-144. <https://www.ijsr.net/getabstract.php?paperid=SR24828021739>
- [94] Sunil Kumar Suvvari & DR. VIMAL DEEP SAXENA. (2024). Innovative Approaches to Project Scheduling: Techniques and Tools. *Innovative Research Thoughts*, 10(2), 133-143. <https://doi.org/10.36676/irt.v10.i2.1481>